

## Electronics on Show

THERE is general agreement that the Instruments, Electronics and Automation Exhibition held recently in London was a success. The organization was good, attendances were high without causing congestion, and the concurrent technical conference, both in the quality of its co-ordinating papers and the liveliness of the subsequent discussions, was far from being a mere token function.

Most of the visitors, including a significant number from overseas, were clearly interested professionally in the details of the products exhibited by manufacturers, and it was noticeable that many standholders seemed fully occupied in making entries in their order books.

Against this background the few members of the general public who had been inveigled into paying their half-crowns for admission by the "popular attractions" billed outside the hall, were rather conspicuous in their bewilderment as they searched for the equivalent of the bearded lady and the three-card trick. We are aware that exhibition organizers are inclined to measure success by the size of the "gate" but we question their wisdom in trying to increase it by posters more appropriate to the fair-ground.

The facts of electronics and automation have already been too much overlaid by fantasy in the popular press and it is to be hoped that in future exhibitions they will be allowed to speak for themselves. This they can well do, more often than not in a way which appeals alike to layman and professional. If a census had been taken of the crowds surrounding the demonstrations of ultrasonic cleaning and drilling, or of the remote handling gear for radioactive materials, as many Ph.D.s would have been found as schoolboys.

It was gratifying to see a number of organized visits by parties of sixth-form scholars and junior technical school students. Through their eyes, some of the computers and control systems must have appeared, as they often do to us, to be of discouraging complexity. More might be done to show that the most complex systems are elaborations of fundamentally simple ideas, of which they may already have some inkling, or which they can reasonably expect to grasp after a little quiet study.

Many potentially valuable recruits to the electronic profession must have been lost at exhibitions of this kind through a lack of confidence in their ability ever to hold their own in what must appear to be such a high plane of intellectual endeavour.

Would it not be a good idea to arrange more demonstrations of the fact that there is plenty of work to be done by young people like themselves? It should not be difficult to stage a replica of a corner of a laboratory or drawing office, staffed by apprentices or junior technicians working on *real* problems of the kind that contribute directly to the production of a piece of commercial equipment.

In this age of technological expansion, not the least important functions of an exhibition should be to foster the enthusiasm of the younger generation and to bring into perspective the notions of the adult "layman." (In this category must be placed at least one clergyman whom we saw making a purposeful stand-to-stand tour of the exhibits.)

This important work cannot always be safely entrusted to the sales department, which is generally responsible for staffing the exhibition stand, and we commend the tact of those firms who conduct their sales campaigns in inner offices and who regard the time of senior technical staff as well spent in taking turns as "front men" on the stand. They alone are capable of handling effectively the searching enquiries of potential customers and of dealing sympathetically with what, to less experienced minds, may seem to be the naive questions of the younger generation. Taking the longer view, the latter may be by far the more important, for at an impressionable age a thread of memory may be established which in time may result in the recruitment to the firm of a fully qualified technician ready to begin the most productive years of his career.

### Can We Help?

NOT long ago three London functions, each drawing its supporters from the same group of people, were held on the same date. This contretemps prompts us to offer, and by wider use to improve, our services to organizers of meetings, conferences, dinners, etc., as a "clearing house." On the occasion referred to, it was unfortunate that one of the organizations had consulted us before fixing this particular meeting, and had in fact altered the date to avoid embarrassment to another, only to find ultimately that they clashed with a third, of which, at that time, we had no knowledge.

With more functions than available dates, it is impossible to avoid some overlapping, but *Wireless World* will be happy to use its offices to minimize the number of special functions with similar interests arranged for a particular date.

# Horizontal versus Vertical

## SUBJECTIVE FACTORS INFLUENCING THE CHOICE OF

**T**HE balance between horizontal and vertical resolution in picture reproduction is once again a topic of conversation, and in view of its impact on the choice of future monochrome and colour television standards, it would perhaps be as well to state clearly exactly what is known about the subject and how much is still a matter of conjecture.

The problem resolves itself into two parts which can be put in the form of questions:—

The first is “What is the best compromise between vertical and horizontal resolution for picture reproduction that will satisfy the average observer?”

The second is “What is the best choice of television scanning standards for any given bandwidth to achieve this?” This involves such factors as the number of lines, the question of interlacing, the use of spot-wobble and, in the case of colour television, the choice of chrominance bandwidth and the effects of crosstalk if the chrominance information is carried to any extent inside the luminance channel.

To deal with the first question, there seems to be no doubt that when picture sharpness is being considered, the most desirable choice is equality of resolution in horizontal, vertical and any other directions for a “structureless” type of picture. The “equality” under discussion is the degree of sharpness in the various directions. A photographic reproduction of any normal type would be representative of a “structureless” type of image, as it is composed of a random arrangement of grains which show no regular pattern. The centre of the field of a normal photographic image is equally sharp in all directions. On the other hand, in a television picture there is a definite structure of a most unsymmetrical kind due to the scanning lines. In this case there seems to be no simple method of measuring equality of sharpness in various directions, particularly vertically and horizontally.

It has been common practice for many years to assess sharpness by means of “resolution charts.” Unfortunately, these have recently been shown by photographic research workers to be most misleading. Test objects consisting of alternate black and white lines of equal width have been used for these measurements and a “lines per mm” figure represents the closest spacing which the photographic process is capable of resolving. The interesting point which has emerged is that two photographic processes, for example, can have a “lines per mm” rating in the ratio of 2:1 or more, and the process with the lower rating, i.e., lower resolving power, can produce an apparently sharper picture. In this particular example the two processes would use widely differing photographic emulsions, having different degrees of contrast, tone range, etc., which independently affect apparent sharpness. Resolution charts are not always misleading, however, and with the same or closely similar processes they are capable of giving reliable *comparative* readings. That is to say, sharpness would increase with resolving power measured by a resolution chart, other things being equal. With a picture containing “structure,” how-

ever, particularly if such “structure” has a strong bias in one direction, such as the scanning lines of a television picture, then the use of resolution charts to compare sharpness in two directions must be considered with very great caution.

The reasons for asserting that sharpness should preferably be equal in all directions are as follows:—

There does not appear to be any evidence to suggest that human vision is significantly preferentially astigmatic on the average. According to an eminent eye specialist consulted by the author, 70% of “normal” people are entirely free of any astigmatism. Of the remainder there is a slight preponderance with higher acuity in the horizontal rather than the vertical direction. In prescribing spectacles for correcting astigmatism, it is the usual practice to equalize the resolving power in all directions. The results of tests carried out by N. R. Phelps and the author on teams of observers have shown no serious preferential astigmatism. The average showed a 6% greater horizontal acuity compared with vertical. From this it may be concluded that if there is in fact any greater resolving power in the horizontal direction, it is sufficiently small to have no effect. The difference in acuity would have to be of the order of 25% to be worth considering when choosing television standards.

The objects which we look at in an average scene are not in themselves less sharp in one direction than in another. One would expect the average observer by force of habit to be most content with a reproduction which is equally sharp in all directions.

From our knowledge of the mechanism of human vision, therefore, there does not seem to be anything very unsymmetrical about it which would encourage the idea that in picture reproduction there is any preference for a greater degree of sharpness in one direction than in another.

### Stereoscopic Viewpoint

There is one interesting angle on the situation which has been suggested to the author by a professor of optics. In stereoscopic vision, part of the information which the brain uses in assessing depth in a scene is provided by the difference between the left and right eye images. Due to the horizontal arrangement of the two eyes, the assessment of depth by this method must obviously use information given only by the vertical edges of objects. Horizontal edges will produce no difference in the two images which can be made use of by the brain. The information conveyed by the difference between the images in the two eyes is of course only a part of the whole appraisal of depth, which includes comparison of the sizes of objects, parallax and the information given by the focusing of the lens of the eye. However, if there was any requirement for preferentially sharper vertical edges in a reproduction, due to this possibility, it would more properly apply to a stereoscopic (“3-D”) picture than to a two-dimensional one such as we are at present considering.

# Resolution

By L. C. JESTY\* B.Sc., M.I.E.E.

## FUTURE TELEVISION STANDARDS

The most important single piece of experimental evidence available in favour of equality of vertical and horizontal picture sharpness is that given in the classic paper by M. W. Baldwin Jnr., of Bell Telephone Laboratories, published in 1940<sup>(1)</sup>. Baldwin conducted a series of observer tests, using an accurately controllable film projector as his picture source. The picture was capable of being defocused selectively in the vertical and horizontal directions by calibrated cylindrical lens elements attached to the main projection lens. The observers were asked to state their preference for pictures projected under different conditions. A "just noticeable difference" in picture quality was called a "liminal" unit. Fig. 5 from Baldwin's paper is reproduced here. This shows that for different standards of absolute sharpness his observer team in every case scored the highest number of "liminal" units for the pictures in which the sharpness was equal in both directions.

Each of Baldwin's curves represents a constant-area picture element. As the diagrams underneath the curves show, the picture element changes from tall and thin to short and fat, passing through the symmetrical equal resolution stage in the middle of the diagram. The area of the element remains constant for a given curve, corresponding approximately to a constant bandwidth television picture with different numbers of lines. The results as they stand of course do not apply *directly* to television pictures since Baldwin's pictures were "structureless" in the sense already referred to. His results provide overwhelming evidence that with structureless moving pictures the average observer prefers equal vertical and horizontal sharpness rather than an increase in one to the detriment of the other.

To sum up the evidence relating to the first question, then, there appear to be no data available to support a theory that an increase in sharpness is more acceptable or more desirable in one direction than another in structureless picture reproduction.

We come now to the second question—"What is the best choice of television scanning standards for any given bandwidth?" This can be reframed more precisely in the form "What is the optimum number of lines for a television system with a given video bandwidth?"

There have been a large number of publications dealing with the resolving power of television systems, beginning with the pioneer work of Mertz and Gray at Bell Telephone Labs<sup>(2)</sup>, and Engstrom at R.C.A.<sup>(3)</sup> The classical approach has been to consider the television picture as composed of individual picture points or picture elements. The number of elements in the height of the picture was originally taken as the number of lines displayed in the picture. The number of elements in the width of the picture is usually taken as twice the number of cycles of the maximum video frequency which can be displayed along each line of the picture.

Neglecting the effect of line structure, it is reasonable to suppose as a first assumption that picture

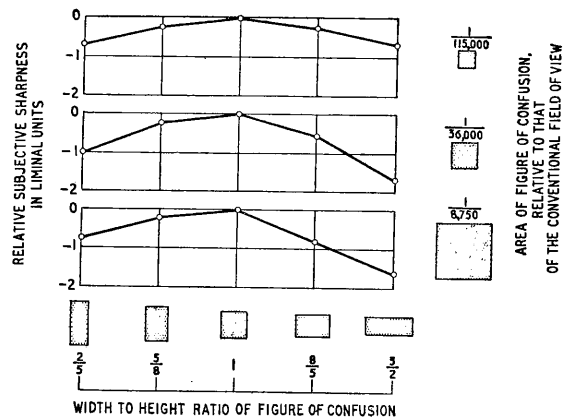

Sharpness of small film pictures as a function of relative horizontal and vertical resolutions. The field of view is a rectangle of height  $1/4$  the viewing distance and width  $4/3$  the height. Each point represents 150 observations at a viewing distance of 30 inches.

sharpness would be closely related to the number of picture elements in the picture, and that the ratio of vertical to horizontal sharpness would be related to the number of picture elements per unit length in these two directions. Taking our present 405-line standard as an example, the number of picture elements in the height of the picture would work out at  $377/3 = 126$  per unit length vertically and  $499/4 = 125$  per unit length horizontally. These two values are virtually the same, and it is not difficult to see, therefore, why a bandwidth of 3 Mc/s was chosen for the 405-line system in 1935 when it was originally proposed. Since then, however, it has become clear that owing to the unsymmetrical structure in the picture due to the horizontal scanning lines, this method of equating the vertical and horizontal sharpness is not valid. The interlacing of the two frames is a further complication.

The fact that a television picture is broken up for the purpose of transmission into a series of scanning lines has the effect of "quantizing" the vertical information in the picture. As Mertz and Gray showed, this results in the generation of "spurious patterns" as limiting resolution is approached, then the nett result is that the vertical resolution attainable with a regularly spaced series of quantized picture elements of this kind is much

\* Sylvania-Thorn Colour Television Laboratories.

less than the number of elements would suggest. As already mentioned, when the separate elements are interlaced in two successive frames and displayed on a cathode-ray screen which has insufficient afterglow to eliminate such effects as line-crawling and interline flicker, then some further reduction in vertical sharpness occurs.

The ratio of the "effective" number of picture elements to the actual number of television lines displayed has been estimated by various investigators in the last 20 years. Values lying between 0.53 and 0.85 have been proposed. This ratio is popularly known as the "Kell factor" as a tribute to Ray Kell of R.C.A., who did much of the original work<sup>(4)</sup>. Baldwin, in his paper, quotes five published values for the Kell factor lying between the above limits and having an average value of 0.71. He himself obtained the value of 0.70 for a sequentially scanned television picture. Some recent work of the author's indicates a value much nearer the lowest figure quoted above (0.53) for interlaced scanning systems.

The horizontal structure of a television picture, i.e., along the lines, is practically negligible even if a fully corrected low-pass filter is used to give a sharp cut to the video frequency spectrum. The effective number of picture points in the horizontal direction, therefore, can generally be taken to be that given by the method used in the 405-line example already quoted. Taking a Kell factor of 0.7, the video bandwidth required for equal vertical and horizontal resolution of a 405-line system would be  $0.7 \times 3.0 \text{ Mc/s} = 2.1 \text{ Mc/s}$ .

The general formula relating video bandwidth and number of lines for equal sharpness in the vertical and horizontal directions is as follows, where  $k$  is the Kell factor,  $v$  is the percentage vertical blanking,  $h$  is the percentage horizontal blanking,  $N$  is the number of lines,  $f$  is the video bandwidth in megacycles per second,  $p$  is the picture frequency per second, and the picture ratio is  $4 \times 3$ —

$$\frac{kN}{3} \left(1 - \frac{v}{100}\right) = \frac{2f10^6}{4pN} \left(1 - \frac{h}{100}\right)$$

$$\text{or: } f = 6.67 \times 10^{-7} p k N^2 \left(1 - \frac{v}{100}\right) / \left(1 - \frac{h}{100}\right)$$

If  $v$  is taken as 7%,  $h$  as 15%, and  $k$  as 0.7, then according to this formula, for the Continental 625-line television system with a picture frequency of 25 per second, the bandwidth for equal vertical and horizontal resolution is 5.0 Mc/s. For the American 525-line, 30-pictures-per-second system, a similar calculation gives 4.2 Mc/s. The actual values incorporated in the respective standards are, of course, 5.0 and 4.0 Mc/s. The standards were, in fact, chosen so as to give, as nearly as possible, equal resolution in the two directions, with the information then available<sup>(5)</sup>. If, however, the Kell factor is nearer to 0.5, then the bandwidths for equal resolution in both directions on the 405-, 525- and 625-line systems would work out to be in the region of 1.5, 3.0 and 3.5 Mc/s respectively. The corresponding bandwidths for the French 819-line system are 8.5 Mc/s ( $k=0.7$ ) and 6.0 Mc/s ( $k=0.5$ ). The video channel allocation is 10.5 Mc/s.

Assuming that a Kell factor of 0.7 is correct for a sequentially scanned television picture, then half this value (0.35) would be correct for a 2-to-1 interlaced picture which completely fails to interlace.

Such a picture, of course, reduces to a sequentially scanned picture with half the number of effective scanning lines. If this assumption is correct then it is important to note that a Kell factor in the region of 0.5 does *not* indicate that there is no advantage in interlacing, but, in fact, shows an improvement of nearly 50% over the completely "paired" scan.

M. W. Baldwin states, and the diagram reproduced here clearly shows, that for the high definition pictures it is quite safe to deviate from the optimum symmetrical resolution condition (symmetrical picture element) by a fairly large amount. Baldwin suggests that it is tolerable to go to a picture element which is a 2-to-1 rectangle in either direction. This would mean, for example, that if the video bandwidth of a 625-line system is adjusted to give equal vertical and horizontal resolution, then the number of lines could be increased to  $625 \times \sqrt{2} = 880$  or reduced to  $625/\sqrt{2} = 440$  without noticeable comment on picture sharpness from the observer. As already emphasized, however, these data were obtained with a structureless picture source and the suggestion that a reduction to 440 lines would be tolerable with this bandwidth would have to be taken with a considerable degree of caution, owing to the effect of the increased "lininess" in the picture.

To sum up the discussion of the second question, then, it would seem that the British 405-line standard was originally chosen to give an equal number of picture elements per unit length in the vertical and horizontal directions, the vertical figure being based on one picture point per scanning line. It is now more generally accepted that owing to the "quantizing" of the information in the vertical direction by the scanning lines, the effective sharpness in this direction is considerably reduced by a factor known as the Kell factor. It was on the basis of a Kell factor of approximately 0.7 that the American 525-line and the C.C.I.R. 625-line standards were chosen. On this reckoning our 405-line system has an excess of horizontal sharpness of about 50% over the vertical.

Some recent experiments of the author's suggest an even lower value for the Kell factor, and furthermore, that observers of television pictures exhibit pronounced "line resistance." By this is meant that if they are offered an increase in video bandwidth for a given line and field rate, they will not take advantage of it once the symmetrical sharpness condition has been passed. These two results independently suggest that for the given bandwidths, all existing standards of television, and especially our own, would profit by an increase in the number of lines.

#### References

- 1 M. W. Baldwin. "The Subjective Sharpness of Simulated Television Images," *Proc. I.R.E.*, 28, No. 10, p. 458 (Oct. 1940).
- 2 P. Mertz and F. Gray. "A Theory of Scanning and its Relation to the Characteristics of the Transmitted Signal in Telephotography and Television," *Bell System Tech. Journal*, 13, p. 464 (July 1934).
- 3 E. W. Engstrom. "A Study of Television Image Characteristics," *Proc. I.R.E.*, 21, p. 1631 (Dec. 1933).
- 4 R. D. Kell, A. V. Bedford and M. A. Trainer. "An Experimental Television System," *Proc. I.R.E.*, 22, p. 1246 (Nov. 1934).
- 5 D. G. Fink. "Television Standards and Practice," McGraw Hill (1943).

# WORLD OF WIRELESS

## Birthdays Honours

A NUMBER of well-known names in the world of wireless appear in the Queen's Birthday Honours List.

Air Marshall R. G. Hart, who was a member of Watson-Watt's Bawdsey team in 1936, and was recently appointed controller of engineering and equipment at the Air Ministry, is appointed a Knight Commander of the Order of the British Empire. Brigadier L. H. Harris, who was for some years controller of research at the Post Office before being appointed engineer-in-chief in 1954, also becomes a K.B.E.

Group Captain E. Fennessy, managing director of Decca Radar, is promoted to C.B.E., and A. T. Black, director of electronic production (munitions), Ministry of Supply, is appointed C.B.E.

Among the new O.B.E.s are: E. H. Betts, deputy controller, telecommunications liaison group, War Office; Captain K. W. James, R.N. (Ret.), senior chief executive officer, Government Communications Headquarters; and Dr. A. R. A. Rendall, head of designs department, B.B.C., who is on the editorial advisory board of our sister journal, *Electronic & Radio Engineer*.

New M.B.E.s include: H. D. Bruce, head of electronics application department, W. H. Smith and Co., Ltd.; W. J. Quill, chief of systems design and planning, radar division, Marconi's; A. J. Smith, chief of production control, commercial engineering factory, E.M.I. Electronics; F. W. Townsend, experimental manufacturing manager, Plessey Company; and A. R. Turnbull, chief radio officer of the floating factory *Southern Harvester*. F. J. Robinson, radio operator at the Post Office station at Highbridge, Som., receives the British Empire Medal.

## Scottish I.T.A.

SERVICE area of the Scottish I.T.A. station, which has been built at Black Hill, Lanarkshire, and is being equipped by Marconi's, will be approximately the same as that of the B.B.C. station at Kirk o' Shotts. To accomplish this its e.r.p. towards Dundee in the N.E. will be 475 kW, towards Ayr 200 kW, and in the N.W. and S.E. 65 kW.

**MEDICAL COLOUR TELEVISION.** American 525-line N.T.S.C. colour standards were seen to advantage in London recently when operations at St. Bartholomew's Hospital were televised and transmitted by microwave link to the Royal College of Surgeons. A three-tube projection system displayed exceptionally good pictures on an 8ft x 6ft screen to a large audience. The demonstration was sponsored by Smith, Kline and French Laboratories, manufacturing chemists, using R.C.A. equipment.

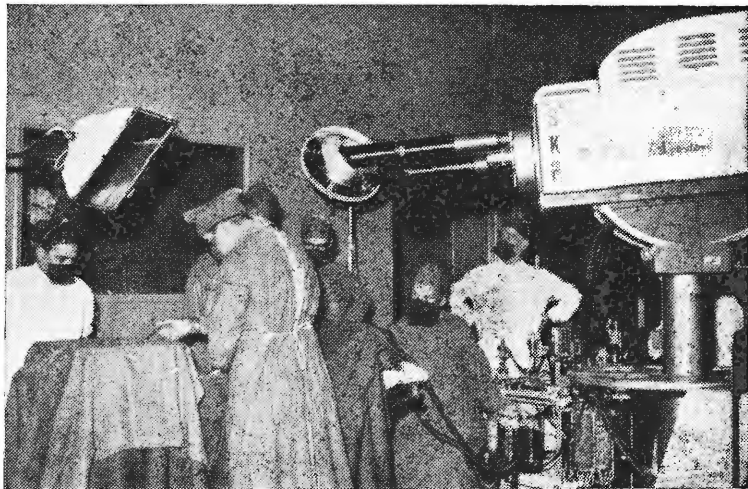

The station, which it is planned to bring into service on August 31st, will operate in channel 10. Test transmissions from a 1-kW pilot transmitter are being radiated each weekday (10.0-12.30 and, except Saturdays, 2.0-5.30 and 7.0-10.0).

**Amateurs and I.G.Y.**—To enable a limited number of amateurs to participate in experiments during the International Geophysical Year (July 1957 to December 1958) the Post Office is "prepared to examine a scheme whereby a small number of amateurs . . . sponsored by the R.S.G.B. could experiment on 144 and 420 Mc/s with higher power than is allowed under the normal amateur licence." Amateurs wishing to participate are invited to write to the Radio Society of Great Britain, New Ruskin House, Little Russell Street, London, W.C.1, marking the envelope "I.G.Y."

**Licence Revenue.**—Figures recently given in the House by the Postmaster-General amend slightly those quoted by "Diallist" in the May issue. They show that 1s 8d of every sound and television licence is retained by the Post Office as a collection charge and a further 7d of each sound licence and 1s 3d of each television licence for interference investigation. The B.B.C. receives 15s 8d (sound) and £2 11s 3d (television). The remaining 2s 1d (sound) and 5s 10d (television) is presumably retained by the Treasury in addition to which there will be the £1 duty imposed on television licences from August 1st.

**Broadcast receiving licences in the United Kingdom** at the end of April totalled 14,559,316, including 7,050,308 for television and 308,296 for car sets. The month's increase in television licences was 84,052.

**Rowridge,** Isle of Wight, v.h.f. sound transmitter, which occupies the same site as the television transmitter, was brought into service by the B.B.C. on June 4th. It operates on 88.5, 90.7 and 92.9 Mc/s with an e.r.p. of 60 kW.

**Orkneys.**—The B.B.C. has applied to the P.M.G. for permission to erect a v.h.f. sound and television station in the Orkneys. It would also serve the north coast of Caithness.

**R.I. Club.**—Membership of the Radio Industries Club increased last year by 55 bringing the total to 940. At the annual general meeting on May 28th Vice-Admiral J. W. S. Dorling, director of the Radio Industry Council, was elected president of the Club in succession to E. K. Cole.

**Radio Industries Ball** will be held at Grosvenor House, Park Lane, London, W.1, on August 30th.

**Next year's Physical Society Exhibition** has been fixed for March 24th to 27th in the Royal Horticultural Society's Halls, London, S.W.1.

**Brit.I.R.E.**—In our note on the armorial bearings granted to the Institution (see page 224, May) we referred to Earl Mountbatten as vice-president of the Institution. Lord Mountbatten has been vice-patron since 1950 having previously held the offices of vice-president and president.

**Radio Controlled Models.**—The annual contests for radio controlled models, organized by the International Radio Controlled Models Society, will be held in the Midlands on August 4th, 5th and 6th. The contests for model aircraft and land vehicles are being held at Wellesbourne Aerodrome, near Stratford-on-Avon, and those for boats at Valley Pool, Bournville, Birmingham. Entry forms and copies of the rules are obtainable from H. Croucher, 27, St. John's Road, Sparkhill, Birmingham, 11.

**Technical Teachers.**—"Industry . . . must be willing to accept, and indeed to encourage and assist, the transfer to full-time teaching work of experienced staff it can ill afford to lose . . . . It must become commonplace for individuals to move from industrial to teaching employment and vice versa." This is one of the main recommendations for improving the supply and training of technical college teachers given in a report of a committee set up in 1956 by the Minister of Education, under the chairmanship of Dr. Willis Jackson. The report, "The Supply and Training of Teachers for Technical Colleges" (H.M.S.O.), costs 4s.

**Plastics materials** in one form or another are being used to an ever-increasing extent in the radio and electronics industry, and many of these applications will be seen at the British Plastics Exhibition which opens at Olympia on July 10th. Free tickets for admission to the Convention, which is being held in conjunction with the Exhibition, are obtainable from *British Plastics*, Dorset House, Stamford Street, London, S.E.1. Admission to the Exhibition costs 2s 6d.

**Trade Ambassadors.**—Business men on overseas visits are frequently invited to talk on U.K. industry and commerce in general. They may, therefore, like to know that a number of booklets dealing with Britain and the Commonwealth are being issued by the Central Office of Information.

**Nottingham Audio Fair.**—Approximately 6,000 people visited the Audio Fair sponsored by Alex Owen, Ltd., at Queen's Hall, Nottingham, from May 26th to 28th. Thirty-two firms exhibited and the B.B.C. provided demonstrations of v.h.f. reception.

"**Opportunities in Electronics,**" a 28-page brochure, issued by Mullard's, shows the science graduate and student what the company has to offer in the field of electronics.

**Catalogues Wanted.**—The librarian of the College of Technology, Gosta Green, Birmingham, 4, invites manufacturers to send catalogues for inclusion in the College library.

It is proposed to start a radio club in the Northfield Secondary School, Aberdeen, and offers of **unwanted components**, however obsolete, will be gratefully received by G. D. Pearson, principal teacher of science at the school.

**Automation and Computation.**—As a result of the meetings between representatives of the Institutions of Civil, Mechanical and Electrical Engineers earlier this year, a "Conference on Automation and Computation" has been set up to provide liaison between interested organizations. The consortium, at present comprising some twenty organizations, will be organized in three groups of societies covering (a) engineering applications of automation techniques, (b) development and applications of computers, automatic controls and programming techniques, and (c) sociological and economic aspects. All societies interested in automation may apply for membership of the appropriate group to the I.E.E., Savoy Place, London, W.C.2.

**Women's Engineering Society** is organizing a conference on "Careers for Girls in Engineering" at the Coventry Training College for the week-end, July 13th/14th, to which representatives of industry, schools, training colleges and the Youth Employment Service are invited. Among the speakers will be Dr. Willis Jackson (director of research and education, Metropolitan-Vickers) and Mrs. R. West (electronic development engineer, G.E.C., Coventry). The Conference fee is £2 17s 6d and application forms are obtainable from The Women's Engineering Society, 26, Victoria Street, London, S.W.1.

**Institution of Electronics** is holding a meeting in the Beveridge Hall, Senate House, University of London, W.C.1, at 6.0 on July 5th, when Dr. P. B. Fellgett and B. V. Somes-Charlton will speak on television in astronomy. The annual exhibition and convention organized by the Northern Division of the Institution will be held at the College of Science and Technology, Manchester, from July 11th to 17th. Complimentary tickets for the London meeting and the exhibition are obtainable from W. Birtwistle, 78, Shaw Road, Rochdale, Lancs.

**Radio Astronomy.**—The British Astronomical Association has recently formed a Radio Physics Section to deal with the problems of radio astronomy and electronic devices for amateur astronomers. The secretary is J. C. Codling, of 35, London Road, St. Albans, Herts.

**Inaugural meeting** of the Institute of Automation was held at the Junior Institute of Engineers, Westminster, on May 11th. Information is obtainable from the secretary, A. L. Jackson, 118, Westwood Park, London, S.E.23.

**Educational wallchart**, entitled "Classification of Electronic Tubes," is available from Mullard free of charge to lecturers and teachers at schools and training establishments. It covers both high-vacuum and gas-filled valves and tubes, and includes thermionic, cold cathode, photo and pool cathode emission. It is obtainable from Mullard Educational Service, Mullard House, Torrington Place, London, W.C.1.

## FROM ABROAD

**Cybernetics.**—As a result of the International Congress of Cybernetics held at Namur, Belgium, last year, the International Association of Cybernetics was established in January and now has over 1,000 members from 26 countries. Dr. W. Grey Walter, director of the Department of Physiology at the Burden Neurological Institute, Bristol, is a member of the board of directors. Plans are being made to hold the second International Congress of Cybernetics in September, 1958. Particulars of the Association are obtainable from the secretariat, 13, rue Basse-Marcelle, Namur, Belgium.

**Reception reports** on test transmissions from Geneva are invited by the International Committee of the Red Cross. The broadcasts are being radiated on 7.21 Mc/s on June 25th, 27th, and 29th at 0730, 1300, 1630 and 2200 (B.S.T.). Report forms are obtainable from the British Red Cross Society, 14, Grosvenor Crescent, London, S.W.1.



**German U.H.F. Television.**—The Südwestfunk, which operates the sound and television service in what was the French zone of Germany, has brought into service a television station working in Band IV. It is on the Kinheimer Höhe, near Kröv on the Moselle, and operates on 492.25 Mc/s (vision) and 497.75 Mc/s (sound) with a vision e.r.p. of 2 kW.

**"Semiconductor Electronics."**—This is the title of a new journal being issued in the United States to give a monthly survey of the published literature in the field indicated by its name. It is published by Semiconductor Information Service, Box 407, Boston 39, Massachusetts, and costs \$8 per year.

**Frankfurt Show.**—Transmitting and receiving equipment, components and accessories are being exhibited by West German manufacturers at the Radio, Television and Gramophone Exhibition to be held in Frankfurt from August 2nd to 11th.

**Famous Station's Jubilee.**—Old-timers of the pre-1914 era will remember the German station at Norddeich, on the North Sea coast. In the years around 1911, reception of its signals in England conferred the hall-mark of receiver sensitivity. The original station was built in 1907 by Telefunken, who have just published (through Oberpostdirektion, Hamburg) a commemorative booklet.

**Australasian Contest.**—This year's VK/ZL DX Contest, organized jointly by the Wireless Institute of Australia and the New Zealand Association of Radio Transmitters, will be held during the weekends, October 5th/6th (phone) and 12th/13th (c.w.). Details are obtainable from W.I.A., Box 1234K, G.P.O., Adelaide, South Australia.

**Canadian Convention.**—The second annual convention and exhibition organized by the Canadian sections of the Institute of Radio Engineers is to be held in Toronto from October 16th to 18th.

## PERSONALITIES

**Martin Ryle, F.R.S.**, lecturer in physics at the Cavendish Laboratory, Cambridge, where since the war he has been undertaking radio astronomical research, has been awarded the Hopkins Prize of the Cambridge Philosophical Society for his work on radio astronomy. The prize is awarded every three years, the present award being for 1951-54. Mr. Ryle, who in 1954 received the Hughes Medal of the Royal Society for his work in this field, left Oxford University in 1939, and joined T.R.E., working on radar applications until the end of the war.

**H. A. Lewis, M.B.E., T.D., B.Sc.(Eng.), A.C.G.I., M.I.E.E.**, has been appointed managing director of E.M.I. Sales and Service in succession to the late E. J. Emery. He will, in addition, be commercial director of E.M.I. Electronics. Mr. Lewis resigned from Marconi's, where he was manager of the broadcasting division, last July and joined E.M.I. as personal assistant to Mr. Emery.

**Sir Harold Hartley, G.C.V.O., F.R.S.**, is the new president of the Society of Instrument Technology in succession to A. J. Young, B.A., B.Sc. At the annual general meeting he received the Society's Bowen Prize.

**P. R. Coursey, B.Sc., M.I.E.E., F.Inst.P.**, has retired from the position of technical director of Dubilier, which he has held since 1931. He is remaining on the board as an ordinary director and being retained as a technical consultant. His association with the company began in 1923 when he was appointed chief engineer. Mr. Coursey, who is 65, graduated at University College, London, and during the 1914-18 war was Admiralty inspector of wireless telegraphy in H.M. Auxiliary Patrol. He was for a short time technical research assistant at H.M. Signal School (now A.S.R.E.). From 1920-23 he was on the staff of Wireless Press, who then published *Radio Review*, of which he was for some time assistant editor, and *Wireless World*.

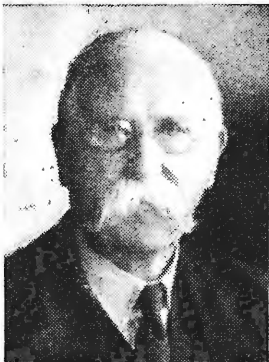

**Edmund H. Cooke-Yarborough, M.A., M.I.E.E.**, contributor of the article in this issue on transistor circuit symbols, recently became head of the electronics division of the Atomic Energy Research Establishment, Harwell. During the war he was at T.R.E. where he was concerned with airborne radar, radar counter-measures and control systems for guided weapons. He joined A.E.R.E. after the war to design electronic equipment and has been particularly concerned with the use of transistors in pulse circuitry.

**Leonard Bennett** has been appointed technical secretary of the Radio and Electronic Component Manufacturers' Association. During the war he was in the signals branch of the R.A.F.

## OBITUARY

**K. W. Tremellen**, who retired from Marconi's W.T. Company in 1952, died in April at the age of 68. Throughout his radio career he had specialized in propagation. After service in the first world war in R.E. Signals, he joined Captain H. J. Round and T. L. Eckersley in the study of long-wave propagation, and made a twelve-month world cruise to assess the possibilities of establishing a chain of long-wave stations throughout the Empire. With the advent of short-wave communications, he naturally turned his attention to the study of propagation at these higher frequencies. It was because of his work in this field that he was appointed scientific officer-in-charge of the Inter-Service Ionospheric Bureau set up at Great Baddow, Essex, in 1941. For his work at the Bureau he was awarded the American Medal of Freedom.

**Dr. Otto M. Böhm**, who came to this country from Germany in 1936 and throughout the war was at the Admiralty Signal and Radar Establishment, died on May 17th at the age of 72. For 13 years prior to coming to England he was technical director of the Telefunken organization, and before joining A.S.R.E. was with Marconi's. He will be remembered in this country for his contributions to the development of radar and in particular his work on the design of aerials on which he contributed a paper ("Cheese Aerials") at the I.E.E. Radiolocation Convention in 1946.

**J. V. Palmer**, for many years manager of the valve division of Mullard Overseas, Ltd., died on April 10th aged 69. He joined Mullard in 1925 and the following year was appointed valve export manager.

**R. C. W. Clarke**, who was in charge of Government contracts for A. H. Hunt (Capacitors), Ltd., which he joined 25 years ago, died on April 19th.

# Multi-Valve Cathode Follower

## I. Methods of Approaching the Ideal Buffer Stage Performance

By J. G. THOMASON, B.Sc.

**T**HE single-valve cathode follower in its basic form is shown in Fig. 1. The input terminal is the triode grid and the output is taken from the cathode. The main features of the circuit are as follows.

- (a) Low output impedance (100 to 1,000 ohms).
- (b) High input impedance (grid-to-cathode leakage path impedance increased 5 to 50 times approx.). Absence of Miller effect.
- (c) Almost unity gain (0.8 to 0.98 approx.).
- (d) The quiescent output voltage, i.e. input connected to earth, is within a few volts of earth potential (2 to 20 volts positive approx.).

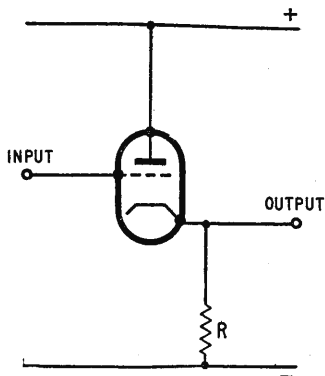

Fig. 1. Basic cathode follower circuit.

- (e) Level frequency response from zero to several Mc/s.
- (f) Good linearity and independence of change in valve characteristics (5 to 50 times reduction in amplitude distortion compared with the same valve operating as amplifier).
- (g) Fluctuations arising from changes in the value of the line voltages appear in the output in con-

siderably reduced magnitude (5 to 50 times less).  
 (h) Extreme simplicity, and economy in components. The numerical values given above cover the range from small receiving valves to output valves of up to about 15 watts anode dissipation.

The cathode follower characteristics differ from those of the same triode connected as a conventional amplifying stage due to the inherent negative feedback introduced by the presence of the cathode load resistor. The amplifying properties of the valve itself are not affected by changing the load resistor from the anode circuit to the cathode circuit, all changes in overall characteristics are due to the feedback. This may be illustrated by comparing Figs. 2 and 3 with Fig. 1. In Fig. 2 the valve is shown connected as a simple amplifying stage, neglecting biasing and decoupling arrangements.

The input voltage is obtained from a transformer giving, say, a low frequency sine-wave of 1 V r.m.s. Then, typically, the anode voltage waveform would be a sine-wave of 30 V r.m.s. with a phase reversal with respect to the input. In Fig. 3 the load resistor has been moved to the cathode circuit but the transformer is still used to feed the 1 V r.m.s. input *between grid and cathode*, exactly as it did in the circuit of Fig. 2. In the circuit of Fig. 3 the output will still be a sine-wave of 30 V r.m.s.—

there is, of course, no feedback and the triode is *not* being used as a cathode follower. There is, however, no phase-reversal with the circuit in Fig. 3.

Comparison of Figs. 1 and 3 shows that in the cathode follower (Fig. 1) the valve grid-cathode voltage is not the same as the input voltage but is equal to the input voltage minus the output voltage. This means that there is 100% negative feedback.

The cathode follower properties may readily be derived from the characteristics of the conventional triode amplifier using the basic feedback formulæ. The important factor in a feedback system is the loop gain, i.e. the total gain of the forward circuit (amplifier without feedback), cascaded with the feedback circuit. In the cathode follower, the forward circuit gain is  $m$ , the triode stage gain with load resistor  $R$ . As there is 100% negative feedback, the loop gain is also given by  $m$ . The usual formula for stage gain gives,

$$m = \frac{g_m R r_a}{R + r_a} \dots \dots \dots (1)$$

where  $r_a$  is the valve anode a.c. resistance, and  $g_m$  is the mutual conductance.

The change in overall gain when a feedback connection is made is found using the parameter  $(1 + \text{loop gain})$ , sometimes called the feedback factor. The overall gain  $G$  with feedback is obtained by dividing the forward gain by the feedback factor,

$$G = \frac{m}{1 + m} \dots \dots \dots (2)$$

Using equation (1),  $G$  may be expressed

$$G = \frac{\mu R}{(\mu + 1) R + r_a} \dots \dots \dots (3)$$

where  $\mu$  is the valve amplification factor, (equal to  $g_m r_a$ ). The 12AX7 high- $\mu$  triode, for example, when worked with a 330 k $\Omega$  load, from a 300-volt line, is found to give a stage gain of about 65, and using this value for  $m$ , equation (2) gives the overall gain  $G = 65/(1 + 65) \approx 0.985$ .

A medium- $\mu$  valve such as the 12AT7 would give, say,  $m = 30$  and therefore  $G \approx 0.967$ . A power valve such as the PX4 might have  $m = 3$  and therefore  $G = 0.75$ .

The type of feedback inherent in the cathode

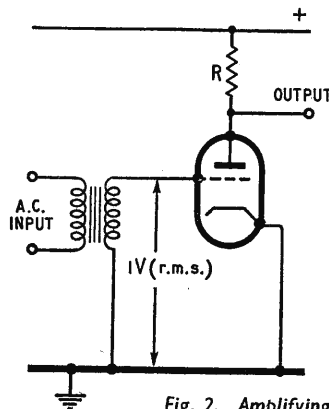

Fig. 2. Amplifying stage with anode load.



# Circuits

One of the most important applications of the cathode follower is as a buffer stage to prevent loading of a high-impedance circuit by a cascaded low-impedance circuit. The basic cathode follower must be elaborated for some of the more exacting applications (e.g. analogue computers) to determine the overall gain with higher accuracy, to remove the d.c. bias between input and output and to alleviate drift due to valve ageing and supply voltage changes.

follower connection is classified as series voltage negative feedback. The series connection implies that the output voltage appears in series with the input voltage, causing the input impedance to be increased in magnitude by the feedback factor. The voltage feedback connection implies that the output impedance will be reduced in magnitude by the feedback factor. The simple triode stage shown in Fig. 2 has an output impedance  $R'$  given by

$$R' = \frac{Rr_a}{r_a + R} \quad \dots \quad (4)$$

The output impedance  $R''$  of the cathode follower is found by dividing  $R'$  by the feedback factor  $(1+m)$ . Using the formula for  $m$  given in (1),  $R''$  may be written

$$R'' = \frac{R'}{1+m} = \frac{Rr_a}{R + r_a + g_m Rr_a} \quad \dots \quad (5)$$

The formulæ for  $R'$  and  $R''$  may be expressed:

$$\frac{1}{R'} = \frac{1}{R} + \frac{1}{r_a} \quad \dots \quad (6)$$

$$\text{and } \frac{1}{R''} = \frac{1}{R} + \frac{1}{r_a} + g_m \quad \dots \quad (7)$$

In this form the formulæ show how, in the case of the simple triode stage the output impedance is effectively made up from the anode impedance and load impedance in parallel and that with the feedback connection, a further impedance of  $1/g_m$  also appears in parallel. Usually  $1/g_m$  is much smaller than  $R$  and  $r_a$ , normally 100 to 1,000 ohms compared with several kilohms, so that (5) may usually be approximated by:—

$$R'' \approx \frac{1}{g_m} \quad \dots \quad (8)$$

The fraction of the input admittance due to grid-cathode resistance and stray capacitance is reduced by the series negative feedback connection, again by the factor  $(1 + \text{loop gain})$ . In the 12AX7, for example, the input capacitance as a normal triode stage might be composed of anode-grid capacitance 1.7 pF and cathode-grid capacitance 1.6 pF. Multiplying the anode-grid capacitance by  $(1 + \text{stage gain})$  to allow for the Miller effect, assuming a stage gain of 65, the total input capacitance works out to 113.8 pF.

As a cathode follower the total effective input capacitance works out to be 1.72(4) pF, due to the absence of the Miller effect and the reduction by a factor 66 of the cathode-grid capacitance. Of course, wiring capacitance, say 5 pF, should be added to both figures.

The increase in cathode-grid resistance can be swamped by the stray resistances in parallel, e.g., anode-grid and grid-earth valve-base leakages, if poor quality components are used.

These properties are seen to make the cathode follower well suited for use as a "buffer" stage, i.e.,

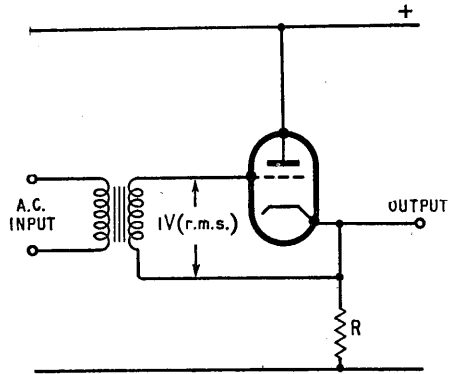

Fig. 3. Amplifying stage with cathode load.

a stage used between two circuits solely to prevent either from being influenced by the other. The simplest case is to prevent a low impedance circuit from imposing an unacceptable load on a high impedance circuit. An example of this application is the use of a cathode follower as an oscilloscope probe. A small probe unit containing the cathode follower is placed as close as possible to the point where it is desired to connect the oscilloscope. The increased input impedance enables the capacitive load on the circuit under test to be kept down to about 10 pF instead of the 200 pF capacitance of the average oscilloscope circuitry. Similarly, the output lead from the cathode follower to the oscilloscope is fed by too low an impedance for capacitive pick-up to be serious. Sometimes it is convenient to screen this lead and the extra screen capacitance may be charged up by the cathode follower without affecting the loading caused by the probe or the frequency response.

In precision circuits, however, the residual imperfections of the cathode follower compared with an ideal buffer stage are important and circuits have been developed which are based on the simple cathode follower but which are superior in one or more properties.

The ideal buffer stage would have the following characteristics

- (a) Zero output impedance.
- (b) Infinite input impedance.
- (c) Unity gain.
- (d) Zero quiescent voltage.
- (e) Level response at all frequencies.
- (f) Perfect linearity.
- (g) Signal handling capacity\* at least equal to the largest signal level in the system.

In the cathode follower, negative feedback is used

\* Signal handling capacity is defined here as the maximum useful current change which the valve can be made to give—the upper limit being defined by the reaching of some arbitrary value of grid current and the lower limit by the reaching of some value of mutual conductance which is an arbitrary fraction below the mid-cycle value.

to change the valve amplifier properties towards achieving those of the ideal buffer stage. Apart from the limitations due to finite feedback factor, however, the basic cathode follower also suffers from drift (slow change of contact potential\*) and has only the signal handling capacity of the same triode connected as a simple amplifying stage.

In certain circuit work, including particularly the analogue computer field, the departures of cathode follower characteristics from those of an ideal buffer stage can sometimes rule out the application of the basic triode cathode follower shown in Fig. 1. In the case where buffer stages are needed between each of many cascaded circuits, particularly with operation down to zero frequency (z.f.), the cumulative drift and quiescent voltage shift are often more troublesome than the overall attenuation. For example consider 10 cascaded cathode followers, each using half of the 12AT7 valve, connected as in Fig. 1, with load resistors of 68 kΩ, drawing 4.4 mA from positive and negative lines of +300 V and -300 V respectively. The individual gains will be about 0.967 ( $m = 30$ ) and the voltage shifts about 4 V, giving

\* Contact potential may conveniently be visualized as the voltage produced by a fictitious generator in series with the grid of an ideal valve. In fact, the d.c. component of the contact potential is a property of the space charge and the random fluctuations are due to physical and chemical changes occurring at the surface of the cathode.

overall values of 0.71 and 40 V respectively. The output drift will be 10 times that of a single valve (about 0.25 V per valve per 10% change in heater voltage).

It is worth mentioning in passing that there is a very economical modification to the cathode follower which avoids the quiescent voltage difference between input and output. The load resistor R in Fig. 1 may be divided into two parts, as shown in Fig. 4, where the upper resistor is arranged to drop exactly the same voltage as the valve grid bias (equal to the quiescent output voltage). The output is now taken from the junction of the resistors, and by adjusting the value of the upper resistor the cathode follower may be set up with quiescent input and output voltages equal. The output impedance is increased with this modification to the circuit, by an amount approximately equal to the value of the upper resistor. The

value usually happens to be about  $\frac{1}{g_m}$  ohms and the

output impedance may be said to have been approximately doubled by the modification. It is seen that there is also a further slight loss in overall gain due to the potentiometer formed by the two load resistors.

With a.c. working it is often convenient to feed the cathode follower grid via a capacitor and return a grid leak to this resistor junction. There is now very little feedback at z.f. and the load current is not accurately set by the feedback as in the circuit of Fig. 1. The quiescent valve current will set itself to the same value as that in a triode voltage amplifier with the upper resistor used for cathode bias and the lower resistor as a conventional anode load. With the grid leak, for a.c. working, it is usual to dispense with the negative line, since quiescent voltages will be of no importance.

### Elaboration of the Single Valve Cathode Follower.

The single valve cathode follower shown in Fig. 1 may be made to give an improved performance if a pentode is substituted for the triode. In general, a pentode may be made to give a higher stage gain than a triode of the same power rating, and this increased forward circuit gain means a relatively higher loop gain, giving a higher feedback factor and therefore enhanced negative feedback properties.

Direct substitution of a pentode for the triode in Fig. 1 would necessitate strapping of the anode and screen and therefore give triode characteristics. It is necessary to provide a constant voltage difference between screen and cathode, as with anode load operation, since the pentode depends on this condition for its characteristics. This means that changes in cathode voltage must be superposed on the quiescent screen voltage.

Circuits where voltage changes on one valve electrode are superposed on the steady voltage at another are known as "bootstrap" circuits and an example of a d.c. bootstrap pentode cathode follower is shown in Fig. 5. The neon tube is fed with 2 mA from a high-voltage positive line and it is seen that this neon holds the screen 150 V more positive than the cathode for all working values of cathode voltage, say -150 V to +150 V. Disadvantages of the circuit, apart from increased power consumption and number of components, are the increased capacitive load on the cathode and enforced reduction in value of load

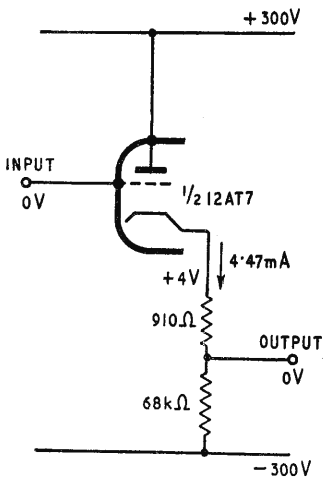

Left: Fig. 4. Cathode follower circuit modified to give zero quiescent output voltage.

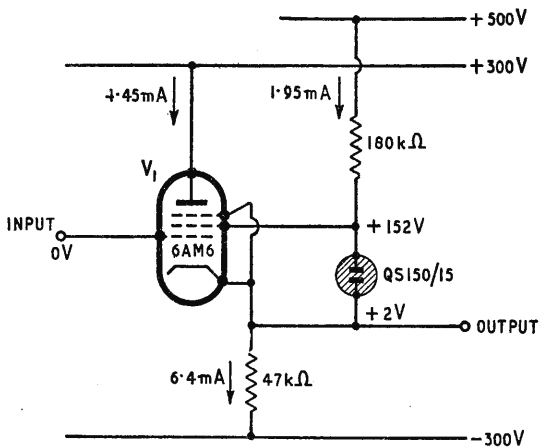

Below: Fig. 5. D.C. bootstrap cathode follower.

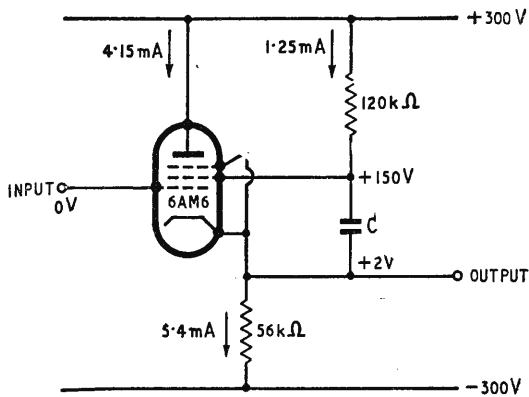

Fig. 6. A.C. bootstrap cathode follower.

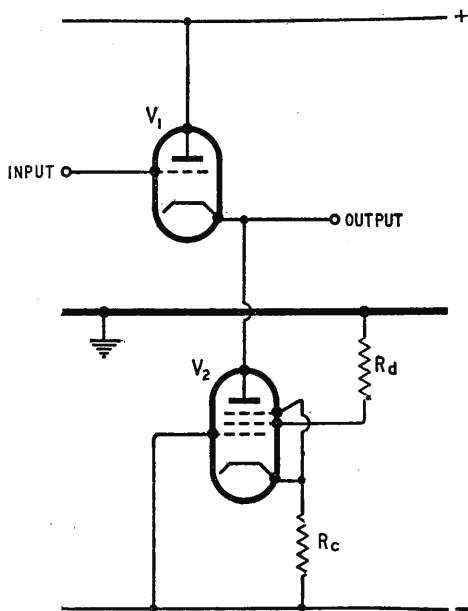

Fig. 7. Constant-current cathode follower.

resistance to allow for the neon tube current, resulting in a lower value of  $m$ .

An a.c. version of the circuit is shown in Fig. 6, where the capacitor  $C$  holds the cathode-screen voltage substantially constant for times short compared with  $CR_s$ , where  $R_s$  is the differential screen-cathode resistance and screen decoupling resistance in parallel. For a value of  $C$  equal to  $0.1 \mu\text{F}$  in the circuit of Fig. 6, pentode operation could be assumed for frequencies down to about 200 c/s. Both these bootstrap circuits give a loop gain of about 150. The signal handling capacity of both circuits is now equal to that of the same valve working as a conventional single-stage pentode voltage amplifier, this being, in general, larger than that of a triode of similar power rating.

The way in which signal handling capacity is determined may be visualized by considering the circuit of Fig. 1. As the input voltage rises, the cathode voltage follows, the difference between the two automatically decreasing by just the right amount to turn on the extra valve current due to the

increased voltage across the load resistor. However, the valve is being asked to pass more current with less anode-cathode voltage, and it is seen that at a certain limiting positive input voltage, the valve will need to draw grid current in order to turn on the required cathode current. Similarly, for negative input voltages the valve is asked to pass less current with an increased anode-cathode voltage. This means that the working point on the mutual characteristic will be forced into the low-current, low-slope region, giving reduced valve gain and therefore reduced feedback.

One way in which the signal handling capacity may be increased is to make the valve current constant over the working cycle. This is conveniently achieved by replacing the load resistor by a pentode as shown in Fig. 7. Typical pentode anode characteristics show that the pentode  $V_2$  passes a current determined mainly by the line voltages and the value of the screen decoupling resistor  $R_d$ . Changes in the cathode follower output voltage, i.e., the pentode anode voltage, have little effect on the current. The resistor  $R_c$  provides cathode bias and the screen is conveniently supplied from earth as shown. The limit of positive excursion is made higher since no increase in current is required when  $V_1$  anode-cathode voltage is reduced and the limit of negative excursion is usually set by "bottoming" in  $V_2$ .

This circuit also gives a higher loop gain compared with the resistor load since the triode  $V_1$  works with a load equal to the high differential anode impedance of the pentode  $V_2$ , so that the stage gain  $m$  closely approaches the amplification factor  $\mu$ . If a bootstrap-connected pentode were used for  $V_1$ , a stage gain of about half the pentode  $\mu$  could be realized, e.g., about 3,000 for the 6AM6. A two-pentode circuit of this type with a.c. bootstrap decoupling is frequently used in cathode-ray tube monitor probes with the advantage that the constant load current gives a constant output rate with fast negative edges at all voltages within the working excursion.

(To be continued)

## Textbook on Polythene

SINCE the early days of the war when the first samples of polythene made such a significant contribution to the success of our airborne radar equipment, the production of this unique plastic has risen from a few hundred to well over half a million tons per annum, and a vast industry has been established on the basis of its mechanical as well as its electrical properties.

A comprehensive treatise with contributions from no fewer than 38 specialists in the many branches of its chemistry, manufacture and fabrication has been compiled under the joint editorship of A. Renfrew (I.C.I.) and Phillip Morgan (*British Plastics*), and is likely to remain the standard work of reference for very many years to come.

Much useful information is given on the effects of antioxidants and other additive materials on the dielectric properties and of recent developments in the modification of properties by halogens and by irradiation. The sections on moulding, extrusion, coating and film production form an invaluable guide to the feasibility of new applications of this versatile polymer.

"Polythene—The Technology and Uses of Ethylene Polymers" is obtainable from our publishers, Iliffe and Sons, Ltd., price 126s (postage 1s 9d).

# "88-50" PRE-AMPLIFIER

Completing the Design for a 50-Watt Amplifier

W. Ian HEATH,\* B.Sc.(Eng.) and D. M. LEAKY,\* B.Sc.(Eng.)

**T**HIS pre-amplifier for the "88-50" mains amplifier described in the April issue is intended to offer full playback facilities from any known programme source and yet utilize circuits which are basically simple and economic. It will operate directly from a gramophone pickup, a high-impedance magnetic tape replay head, a high-impedance microphone or a radio tuner. A selector switch which enables any of these sources to be chosen

also automatically alters the input sensitivity and frequency response compensation to that required for each type of input. This enables the different inputs to be selected and played without immediate alterations to the remaining knobs which are intended to give convenient control of balance and frequency range to suit listening conditions and programme quality. A rumble filter is incorporated which attenuates unwanted motor rumble below 30c/s and removes the risk of overloading the power amplifier and loudspeakers due to this cause.

\* Research Laboratories of the General Electric Co., Ltd.

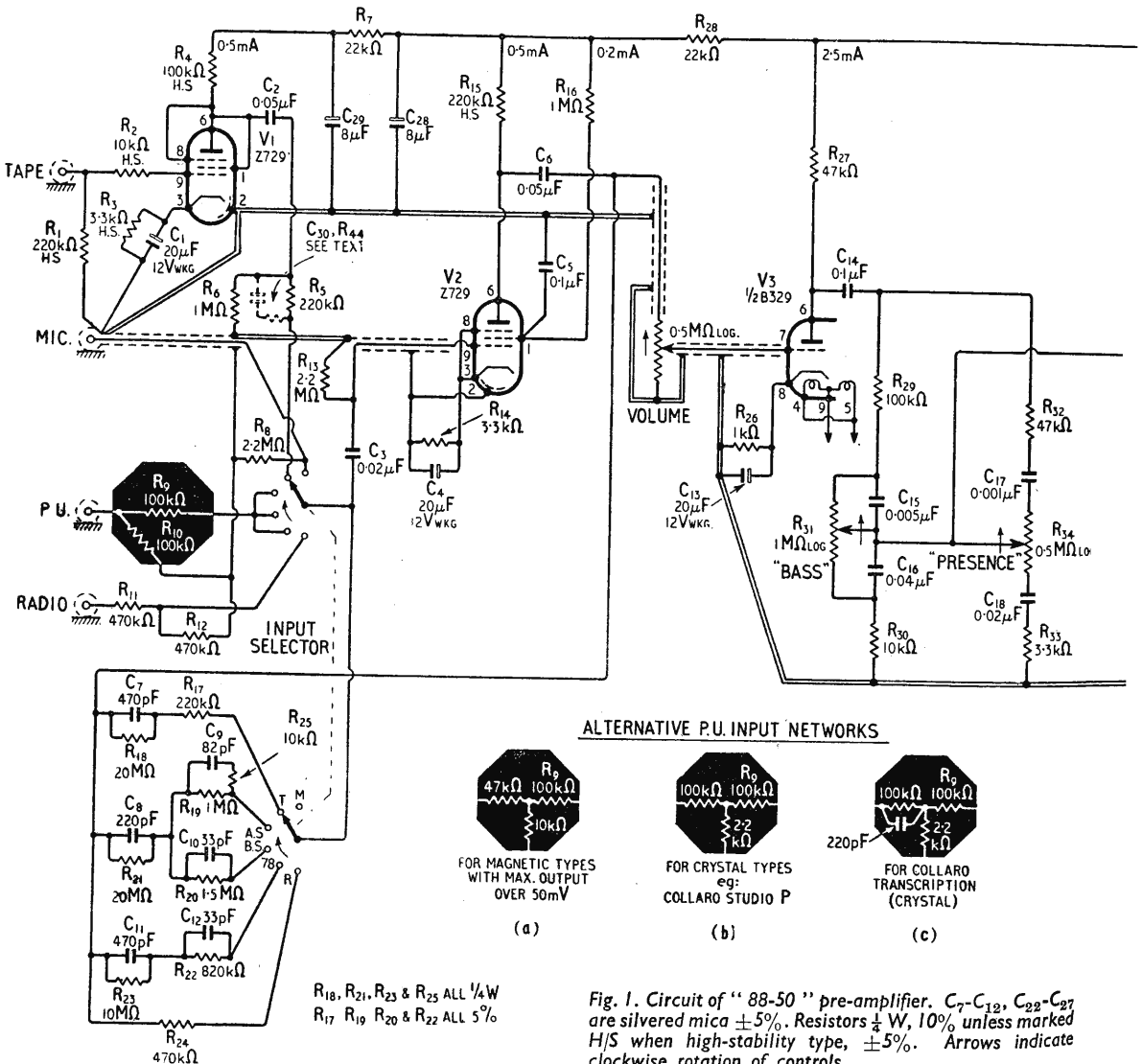

Fig. 1. Circuit of "88-50" pre-amplifier. C<sub>7</sub>-C<sub>12</sub>, C<sub>22</sub>-C<sub>27</sub> are silvered mica ±5%. Resistors 1/4 W, 10% unless marked H/S when high-stability type, ±5%. Arrows indicate clockwise rotation of controls.

The pre-amplifier is designed to give an output of 0.5 volt r.m.s. for maximum signal level, and this corresponds to the input required by the "88-50" power amplifier to give maximum power output. H.T. and l.t. supplies are derived from the power amplifier, and connection is via octal plugs and sockets with a multi-core cable.

The design utilizes negative feedback to keep harmonic distortion low. All the controls use simple resistance-capacitance circuits incorporated either between stages or in the negative feedback loops, and the wiring is not unduly complicated. Apart from the equalizing of initially differing programme sources by means of the selector switch, the use of continuously variable controls for "Bass," "Presence," and "Treble Slope" helps circuit simplification and also removes the bullying effect that switches have on the listener when he is trying to adjust a programme to suit a particular place or occasion.

**Input Selector Circuit.** The first stage of the basic pre-amplifier uses a Z729 valve (V2 in Fig. 1),

	Sensitivity†	Input Resistance	Turn-over Frequency	
			Bass Boost	Treble Cut
1. Radio . . . . .	0.2V	470kΩ	None	None
2. 78 rp.m. records	14mV	50kΩ	400c/s	6kc/s
3. British micro-groove . . . . .	10mV	50kΩ	500c/s	3kc/s
4. American Standard . . . . .	12mV	50kΩ	600c/s	2kc/s
5. Tape (7½in/sec)	4mV	220kΩ	1.5kc/s	—
6. Microphone (high impedance)	1mV	1.1MΩ	None	None

advantage of maintaining the harmonic distortion in the valve at a low level. Between these two extremes any sensitivity can be obtained, and for use with a magnetic gramophone pickup, for example, the necessary frequency response correction to

obtain a "flat" response can be obtained by means of a suitable resistance-capacitance network in the feedback loop, provided the overall correction required is less than the gain of the valve (40dB).

The input selector switch associated with this valve (V2) connects the grid to any of the input sockets, via a suitable network, and simultaneously inserts an appropriate network in the feedback loop between anode and grid. For example, for microphone no feedback is used, and the input resistance consists of  $R_8$  in parallel with the grid leak  $R_{13}$ . For radio the gain is reduced by negative feedback provided by  $R_{24}$  and  $R_{12}$ , and the input resistance is  $R_{11}$ .

The other positions of the switch provide the frequency response corrections necessary when playing from disc or tape recordings, and from all the input sources a "flat" response of roughly similar level is therefore obtained at the volume control which follows this stage.

The prototype pre-amplifier shown here has six input positions. The play-back characteristics chosen were considered to be the most useful half-dozen for general use, but alterations and additions are obviously possible where requirements are different. In clockwise order of rotation the bass and treble turn-over points are shown in the accompanying table, which also gives for each switch position the sensitivity and input resistance at the input socket.

**Tape Compensation.** In the tape position the grid of the Z729 pentode is connected to a tape head amplifier consisting of a Z729, triode connected (V1). This gives the best signal-to-noise ratio

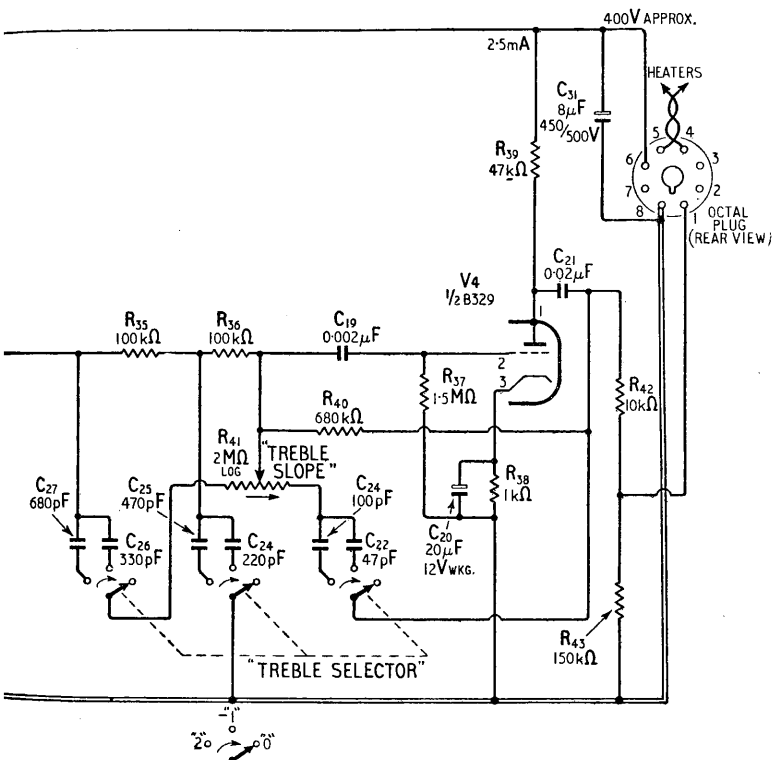

connected as a pentode. This valve was chosen because its freedom from both hum and microphony are essential to obtain a good signal-to-noise ratio. To keep circuit noise low the cathode current is low, and a voltage gain of about 100 (40dB) is obtained. This is sufficient to give without feedback a sensitivity at the grid of 1mV, which is ideal for use with a high-impedance microphone such as a diaphragm-operated crystal type, or for use with a moving-coil microphone and a suitable input transformer. For larger input voltages, such as from a radio tuner, the sensitivity can be reduced by negative feedback, and this has the

†Input for 0.5 volts r.m.s. output from pre-amplifier.

possible, and raises the signal level to a sufficient level to drive the correction stage, V2.

If tape is not to be played the tape head amplifier can be omitted and the spare position on the selector switch used for another record characteristic, or for a low-impedance microphone. In the latter case a screened microphone input transformer can be mounted in the position previously occupied by the valve.

The tape replay characteristic assumes the recommendation that tape should be replayed with a time-constant of 100  $\mu$ sec for 7½ in/sec, and that all treble losses in recording have been compensated by pre-emphasis.† This constitutes a bass boost below 1,500 c/s, see Fig. 4, and is obtained by C<sub>7</sub> and R<sub>17</sub> in the feedback loop. If tape is to be played at other speeds, then these components must be altered as follows:—

Tape Speed	Time-Constant	C <sub>7</sub>	R <sub>17</sub>
3½ in/sec	200 $\mu$ sec	1,000 pF	0.22M $\Omega$
15 in/sec	35 $\mu$ sec	150-220 pF	0.22M $\Omega$

These values could be inserted in other switch positions if more positions are available. The bass boost inherent in these replay characteristics is necessary because the recordings are made with a "constant current" characteristic, i.e., with a high resistance in series with the recording head, so as to produce a constant flux-density characteristic in the tape. It will be noticed that the replay characteristic levels off at a frequency dependent on tape-speed, and this serves to maintain the treble response.

The use of additional treble boost when replaying to compensate for tape losses is undesirable in so far as it makes tape hiss more audible. However, some treble boost on playback is recommended where a poor treble response is due to the playback head itself, and this can be obtained by shunting R<sub>5</sub> by a capacitor C<sub>30</sub> of not more than 100 pF for a tape speed of 7½ in/sec. The effect of this is shown by the dotted curve in Fig. 4. A limiting resistor R<sub>44</sub> in series with C<sub>30</sub> is desirable of about 100k $\Omega$ .

**Disc Compensation.** The three disc record replay characteristics chosen, see Fig. 4, are the American Standard for both microgroove and 78 r.p.m. discs, the British microgroove characteristic which is tending to be displaced by the American, and a compromise 78 r.p.m. characteristic suitable for most European shellac discs, but most resembling the "ffrr" characteristic used by Decca and Brunswick. Only those people possessing 78 r.p.m. discs of earlier origin would desire a second 78 r.p.m. switch position giving bass boost from a lower frequency such as 250 c/s.

The bass boost correction for discs is obtained in a similar way to the tape correction, e.g., for American Standard it is obtained by means of C<sub>3</sub> and R<sub>19</sub>, while the necessary treble roll-off is obtained by C<sub>9</sub>. The limiting resistance R<sub>25</sub> is inserted to promote freedom from instability at very high frequencies. In the prototype amplifier

it was not found necessary to incorporate limiting resistors in the other compensating circuits. The resistor R<sub>21</sub> is connected across C<sub>8</sub> to avoid "clicks" when switching, but it also limits the bass boost correction. If fuller compensation is required between 30 c/s and 60 c/s the value of R<sub>21</sub> should be doubled.

The corrections provided here for disc reproduction are intended for use with any pickup giving an output voltage proportional to recorded velocity. This includes all moving-coil and moving-iron (so called "variable reluctance") types, and the input resistance and sensitivity have been chosen to be suitable for any of the well-known makes with maximum outputs from 10 mV to 50 mV. The input network must be modified however where a pickup is to be used whose output voltage is not proportional to recorded velocity. A crystal pickup is the most common example of this type. It has been found that a very smooth frequency response can be obtained, extending as far as the usual high-frequency peak, if a crystal pickup is connected to an input resistance which is lower than that normally recommended, and the resulting frequency response, which can be made to resemble closely a "velocity" characteristic, is corrected as if a magnetic pickup were being used.

An example is shown in Fig. 5, where the output from a sample Collaro Studio "P" crystal cartridge is plotted against frequency using a test record with a British microgroove characteristic. The response with a 1-M $\Omega$  load approximates to a "flat" response, and is that which is normally used. The response with 0.1 M $\Omega$  shows a fall in bass due to the internal capacitance of the crystal unit, and the resulting curve bears a close resemblance to the British microgroove characteristic which is shown dotted. The exact "fit" of these curves depends on the original response of the pickup, but 0.1 M $\Omega$  is the most suitable value for several other comparable cartridges. Therefore, with a suitable alteration to the input network, incorporating attenuation of the high output voltage, a crystal pickup can be connected to the pre-amplifier and the corrections associated with the selector switch used as with magnetic pickups. The circuit diagram, Fig. 1, shows an alternative input network, inset (b), enabling crystal pickups of this type to be connected, for example the Collaro Studio "P." Inset (c) is suitable for a crystal pickup which has a less pronounced treble peak, the Studio transcription cartridge. Inset (a) is for magnetic pickups having a maximum output greater than 50 mV; note that maximum output is here defined as that given by a recorded velocity of about 7 cm/sec, and corresponds to sections of high modulation on an average disc.

**Bass and "Presence" Controls.** The remainder of the pre-amplifier, including all the "tone" controls, has been economically designed around one double triode. Following the volume control, which is a logarithmic type for smooth control, is the first half (V3) of a B329 valve. This low gain valve is used as a simple triode amplifier without feedback, as this circuit arrangement was found to give the best compromise between distortion and signal-to-noise ratio. It drives a 10 : 1 (20 dB) potentiometer circuit consisting basically of R<sub>29</sub> and R<sub>30</sub>, in which are incorporated the "bass" and "presence"

(Continued on page 317)

†See Amendment No. 1, July 1954, to B.S. 1968: 1953.

controls. Both these are variable potentiometers of logarithmic law so that the "flat" response occurs when the knob is at midposition, and the component values shown are those which gave the flattest midposition curve in the prototype. For the benefit of those who have the test apparatus and inclination to make accurate adjustments,  $C_{16}$  is the bass boost capacitor and operates when not short circuited by potentiometer  $R_{31}$ . Similarly  $C_{18}$  is the treble cut capacitor that gives negative presence when there is no series resistance from potentiometer  $R_{34}$ . With both potentiometers upwards, movement of the slider gives increased bass or presence respectively, and corresponds to clockwise rotation.

**Treble Controls.** From the sliders of the "Bass" and "Presence" controls the signal is amplified in a final triode stage, V4. This is the second half of the B329 valve. Negative feedback is employed consisting of feedback resistance  $R_{40}$  in conjunction with stand-off resistors  $R_{35}$  and  $R_{36}$ . Associated with these resistances are the treble cut capacitors  $C_{22}$ ,  $C_{23}$ ,  $C_{24}$ ,  $C_{25}$  and the treble boost capacitors  $C_{26}$ ,  $C_{27}$ . These may be switched into circuit by the "Treble Selector" switch, in which case the amount of cut or boost may be adjusted by potentiometer  $R_{41}$  which is the "Treble Slope" control.

Minimum treble occurs with the slider to the right in the circuit diagram, and this should correspond with a fully clockwise position of the knob if a logarithmic law potentiometer is used. In this position the treble cut has a maximum asymptotic value of 12 dB per octave. If it is desired to increase treble clockwise then an inverse log potentiometer must be used, but this is not so readily available. On the prototype amplifier a "flat" response was obtained with the knob about  $45^\circ$  from the midposition, on the "boost" side, using a logarithmic potentiometer. The "Treble Slope" control is completely inoperative if the "treble selector" switch is in the "flat" position.

**Rumble Filter.** Incorporated within the feedback loop of V4 are two resistance capacitor coupling networks,  $C_{19}$ ,  $R_{37}$  and  $C_{21}$ ,  $R_{43}$ , each having a time constant of

0.003 sec. The effect of these is to attenuate low frequencies, while their combined phase shift within the feedback loop makes the feedback positive below 50 c/s. The combined effect is to give a flat response down to 30 c/s below which the response falls steeply to a minimum value, at which frequency (about 15 c/s) the coupling capacitors elsewhere in the amplifier are arranged to provide additional attenuation.

The effect of this rumble filter is shown in Fig. 2. If it is desired to attenuate the low frequencies below 40 c/s instead of 30 c/s then  $R_{37}$  and  $R_{43}$  may be changed to 1 M $\Omega$  and 0.1 M $\Omega$  respectively.

In addition to its use for the rumble filter the feedback on V4 maintains its output impedance low over most of the frequency range, and the output impedance of the pre-amplifier is therefore approximately equal to  $R_{42}$ , about 10 k $\Omega$ . Up to 5 feet of ordinary screened cable may therefore be used when connecting to the power amplifier without affecting the high frequency performance.

**Construction.** The construction is novel in that the components are mounted within an open frame, with removable cover plates on both top and bottom. This departure from an orthodox chassis simplifies assembly. For example, the switches can easily be

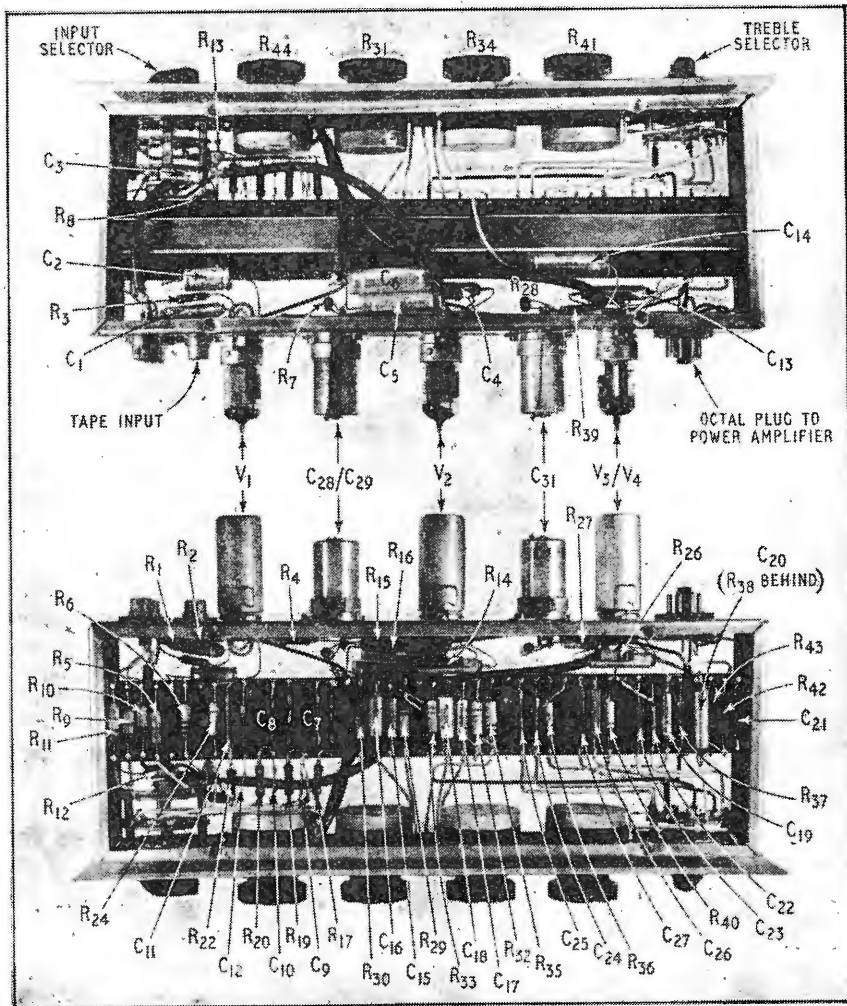

Top and underside views of chassis with covers removed to show layout of principal components.



wired after mounting. The overall dimensions of the basic chassis are 14 in × 5 in × 2 in, with the control knobs spaced 2½ in apart. The edges on both top and bottom are flanged, to a minimum width of ¼ in, so that flat detachable cover plates 14 in × 5 in may be screwed on. In the model photographed hank bushes tapped 6 B.A. were inserted in the flanges, but self-tapping screws could be used. The spacing of the valves and condensers along the rear panel is not critical, but 2 in between centres is suitable, leaving 3 in between either end of the chassis and the nearest valve centre line. At the input end this 3 in space has to accommodate the four co-axial input sockets. At the output end a chassis-mounting octal plug is accommodated.

The prototype chassis was constructed with the rear and two ends in one piece of 16 s.w.g. aluminium, and the front section containing the controls was separately made and screwed on. The front escutcheon panel was made separately to mount only on the control bushes, and was slightly larger than the amplifier, 15 in × 3 in.

The 1½-in tag board contained 44 pairs of tags of which 37½ were required. It was mounted to leave a space of 2 in from the front and 1½ in from the rear. The tag board is mounted on a U-section channel ¾ in × ¼ in which is bolted to each end panel. A wider tag board, while having no advantages, would necessitate a corresponding increase in the 5-inch dimension of the chassis.

The control switches and potentiometers should be mounted on the front. The "input selector" is a 2-pole, 6-position switch, each pole being on a separate wafer for ease of wiring and separation of the circuits. More positions may be included if desired, and a correspondingly greater number of tag board spaces allocated. For easy wiring this switch should be mounted with the slider tag of each wafer next the bottom cover plate. A "spare" insulated tag should be provided on the rear wafer for use as an earth post. The "Treble Selector" is a 3-pole, 3-position switch on a single wafer.

The B9A valve holders and h.t. smoothing condensers should be mounted on the rear, together with the input sockets. These were television aerial input sockets because of their complete screening, and low contact resistance. Jacks may be used where easier plugging is desired, but care must be taken to see that the plugs are of a completely screened all-

metal construction, to avoid hum pick-up, and that all contact surfaces are clean because the contact pressure is low, and oxidation has been found to cause rectification and distortion of the signal. Valve holders should give a reliable pin contact, and should be of a material that will not give internal tracking on high resistance circuits, e.g., polythene or ceramic rather than a "loaded" plastic. The valve holders and the octal supply plug should be mounted with the heater pins, 4 and 5, nearest the lower flange of the rear panel.

**Wiring.** The heater wiring should be completed first. This should be wired in a tightly twisted pair from the octal supply plug, pins 4 and 5, and layed inside the lower flange of the chassis, "looping in" at each valve holder beginning with the B329, V3/V4, and ending with the tape head amplifier, V1. By this means the wiring to the early stages, V1 and V2, carries only the current to those valves, and this reduces the hum field due to the heater wiring to a minimum. The diversion of the twisted wiring at each valve holder must be kept as short as possible, the valve holder tags being used as junction posts to which the "go" and "return" wires are paired together as much as possible. No escutcheon lamp is included in the prototype, and this has enabled all heater wiring to be kept well away from the remainder of the circuit. If a lamp is to be included, it must be wired with a tightly twisted pair directly to the octal supply pins, the wiring must be well separated from the earlier stages, and should preferably be external to the chassis. Neither side of the heater supply is earthed to the pre-amplifier chassis, a centre tap earth being provided near the transformer in the power amplifier.

One earth tag should be screwed to the chassis at the microphone input socket which is the lowest of the three at the end of the rear panel. This is the only chassis connection, apart from the h.t. smoothing capacitors which need not be insulated from their mountings, but must in any case have their negative tags wired as in Fig. 1. The above earth tag will be found convenient for the insulated braiding of the screened lead which connects the microphone socket to the selector switch, and the tag is also spaced by the length of one resistor R<sub>2</sub> from the tape head input socket which is mounted close to the tape head amplifier V1.

The circuit diagram, Fig. 1, indicates how the earthing and other critical wiring is arranged, and this should be closely adhered to. The wiring round V1 should be completed first. The input signal is applied between grid and cathode via the grid stopper R<sub>2</sub> and cathode bypass capacitor C<sub>1</sub> respectively, and it is important that these two components should be positioned with a very small loop area between them. This will minimize the injection of hum from stray a.c. magnetic fields, such as from a nearby

mains transformer. Accordingly R<sub>2</sub> must be wired direct from the input socket to the grid, pin 9, and C<sub>1</sub> direct from the earth tag to the cathode pin 3. The grid leak, R<sub>1</sub>, is wired compactly between the input socket and the earth tag, to which the cathode bias resistor R<sub>3</sub> should also be connected. The centre of the valve

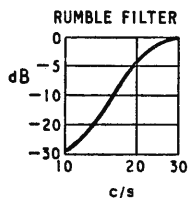
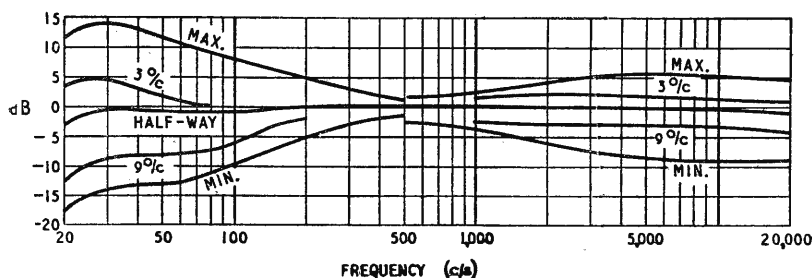

Fig. 2. Frequency response of complete amplifier with "Input Selector" on "Radio," with effect of "Bass" and "Presence" controls. "Treble Selector" at "O."



holder with the "earthy" pin 2 should be connected by an insulated wire to the earth tag, and the negative tag of the h.t. smoothing capacitor  $C_{28}$ ,  $C_{29}$  should be similarly earthed by an insulated wire close to the chassis even if the capacitor case is clamped to chassis. The anode load  $R_4$  is connected direct to  $C_{29}$ , and the coupling capacitor  $C_2$  to the fifth rear tag on the tag board. For minimum circuit noise it is essential that  $R_{11}$ ,  $R_{12}$ ,  $R_3$  and  $R_4$  should be of the high-stability type, and  $C_1$  must be of a type having low leakage current.

The wiring of the selector switch and V2 should now be undertaken. The layout of components will be clear from the circuit and photographs, but a description of the earthing arrangements will be given. A short length of screened lead should be wired to the microphone input socket and its earth tag, and the other end of this connected to the sixth contact of the selector switch (rear wafer). The braiding should be connected to a "spare" insulated tag on the wafer (not connected to the switch frame), and this will act as the sole earthing point of all the input networks. To this earth point is connected the insulated braiding of a second length of screened cable, the inner of which is connected via  $C_3$  to the slider of the rear wafer. This cable terminates at the grid, pin 9, of V2, and the insulated braiding carries earth continuity to the "earthy" pin 2 of this valve. The cathode bypass,  $C_4$  and resistor  $R_{14}$  are soldered compactly across the valve holder between pins 8 and 2 thus giving a very small grid-cathode loop area. This is indicated in the circuit diagram.

The output from V2 is via  $C_6$  to the sixteenth rear tag on the board, and the earthing wire of  $C_{28}$ ,  $C_{29}$  is connected to the seventeenth rear tag. From tags 16 and 17 a short screened lead is taken to the volume control, and from the slider of this a longer screened lead terminates at the grid pin 7 of V3 (B329). The braiding is connected to the "earthy" pin and the "earth line" of all the "tone" control circuits is connected solely to this pin, as also is the octal output plug, pin 8.

The earthing system described above gives continuity from the one chassis connection at the input sockets, via the braiding of screened lead wherever this is used, to the output socket. As the chassis is not used for earth continuity large loop areas between any signal "live" lead and earth are avoided, and hum pick-up from stray a.c. fields is reduced. In the early stages the use of screened lead wherever possible reduces loop area to zero, and where "open" wiring is unavoidable, as in the "input selector" switch, the close proximity of the

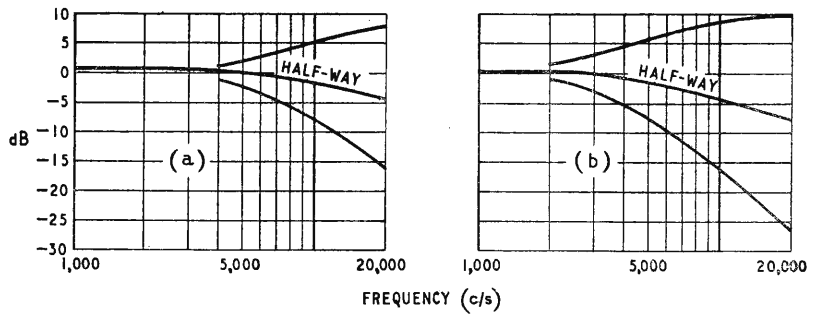

Fig. 3. Effect of "Treble Slope" control with "Treble Selector" at "-1" (a), and at "-2" (b).

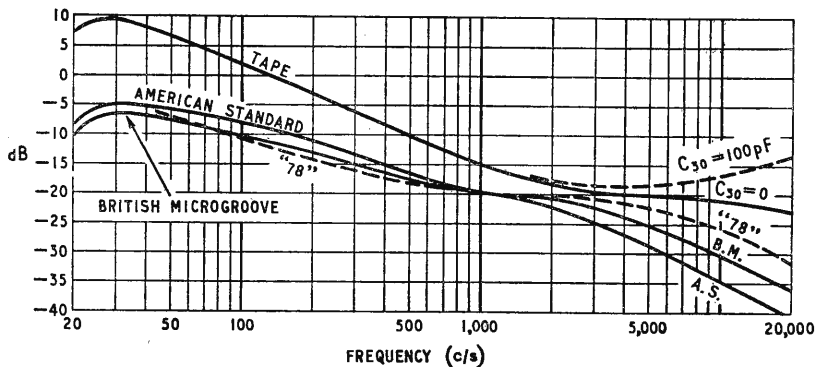

Fig. 4. Disc and tape replay characteristics.

earth circuit reduces loop area to a minimum. Only by this means can hum induced electromagnetically be kept to a minimum, because the enclosure of the circuit by the chassis has no effect on this, although the chassis does provide the necessary electrostatic screening of the "live" portions of the circuit.

**Performance and Operation.** The performance of the pre-amplifier is shown in Figs. 2, 3 and 4. The steep fall in frequency response below 30 c/s shown in Fig. 2 is due to the rumble filter, and the effect of this applies to all inputs.

The "Bass" control (Fig. 2) increases or reduces the bass at frequencies below 300 c/s, and should be used when the "volume control" is set to reproduce speech or music at a level which is unnatural compared with the original. For example, speech reproduced above its natural level will sound too heavy in the bass, and the "bass loudness" should be reduced to restore naturalness. Further reduction of bass is often necessary for public address purposes to improve intelligibility. Music, on the other hand, when reproduced at a level producing less than the original loudness at the ear, sounds lacking in bass and the "bass loudness" should be increased to restore a more normal balance.

The "Presence" control (Fig. 2) alters the level of all frequencies above about 1,500 c/s. It therefore alters the balance between high and low frequencies; an increase in "Presence" giving a more forward incisive quality as if moving the listener nearer to the orchestra or voice. A decrease appears to move the listener farther away, and approximates

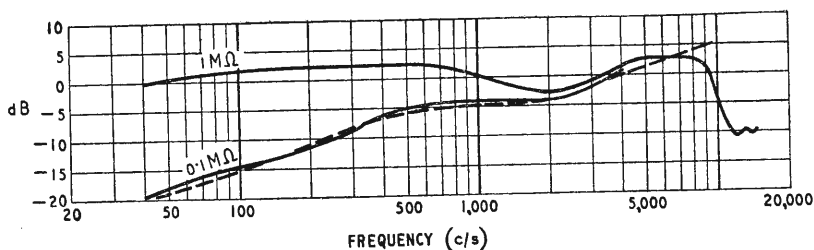

Fig. 5. "Velocity" characteristic obtained from a crystal pickup, the Collaro Studio "P" by using a load of 0.1 MΩ. Velocity characteristic of record (British micro-groove) is shown dotted.

to the effect of sitting at the back of a concert or dance hall.

The two treble controls are intended to be used together for the control of distortion or deficiencies in the programme material above 6 kc/s or 3 kc/s. The "Treble Slope" control operates above either of these two frequencies depending on whether the "Treble Selector" is switched to -1 or -2 respectively. A maximum attenuation slope approaching 12 dB. per octave is available at one end of the "Treble Slope" control, this changing smoothly through a substantially "flat" response to a boost at the other end of nominally 6 dB per octave. The 6 kc/s position is useful for correcting reproduction from tape or microgroove disc recordings. The 3 kc/s position is useful for 78 r.p.m. shellac discs or tape at  $3\frac{3}{4}$  in./sec.

If the "Treble Selector" is switched to "flat," a level response is obtained and the "Treble Slope" control is rendered inoperative.

The component values have been chosen so that if the pointers on the knobs are arranged symmetrically with respect to the maximum and minimum positions, then with all knobs vertical, i.e., half-way round, a flat response is obtained. This arrangement can be seen in the photograph of the front panel, Fig. 1 of the previous article, and forms a convenient reference for using the controls. With the "Treble Slope" vertical slight treble cut is obtained as soon as the "Treble Selector" is moved off the "flat" position.

The power amplifier already described requires 0.5 volts r.m.s. input to drive it to its maximum power output of 50 watts. The pre-amplifier will deliver this voltage, 0.5 volt, at a harmonic distortion comparable with that of the power amplifier. This level of distortion does not deteriorate with variation of the controls, given a programme of reasonably normal balance, and this is assured by the "Input Selector" circuits. To avoid a distortion contribution from the stage V2 before the volume control, all input levels must be adjusted so that full power (50 watts) is not obtained until the volume control is beyond the half-way (vertical) position. This means that an increase of input level nearly 20 dB above the minimum can be accepted without additional distortion.

The pre-amplifier derives its power supplies from the "88-50" power amplifier, and the smoothing in the h.t. supply is chosen to be the minimum required for ripple attenuation, so as to give as high an h.t. line voltage in the pre-amplifier as possible. No h.t. decoupling, additional to the above, is required for stability because the stabilization circuits in the power amplifier, together with its pure push-pull driver circuit, contribute greatly to its freedom from instability at very low frequencies.

The signal-to-noise ratio of the complete amplifier,

relative to 50 watts, is -76 dB, with the volume at minimum and controls "flat" (vertical). With the input sockets short-circuited and the volume control at maximum the following signal-to-noise ratios were measured on the prototype: radio, -69 dB; American Standard disc replay, -63 dB; tape replay, -52 dB; microphone, -55 dB. To achieve these figures when the amplifier is installed in a cabinet all input cables should be of the screened variety, and care must be taken to avoid placing the pre-amplifier too near mains transformers, gramophone motors, etc., and mains supply leads within the cabinet should everywhere be in the form of a twisted pair.

The chassis of the pre-amplifier must not be metallically connected to the chassis of the power amplifier, except via the octal plugs, because the resulting loop would introduce hum. This means that where a metal cabinet is to be used, the front escutcheon panel of the pre-amplifier must be of insulating material. If this is not possible, the input sockets and earth tag (see Fig. 1) must be insulated from the chassis, which must then be separately connected to the power amplifier chassis by a spare pin on the octal plug. It is usually necessary to "earth" the installation, and to avoid loops this must be at one point only, the third pin on the mains supply being suitable in most cases.

#### ADDENDUM

In the previous article dealing with the "88-50" power amplifier, the balance of the push-pull output from the B339 stage is stated to be about 2%. To achieve this it is necessary for the 1 Megohm resistors  $R_8$  and  $R_9$  to be equal, and close tolerance values must therefore be used. More nearly perfect balance is obtainable if  $R_9$  is about 2% higher in value than  $R_8$ , and where a comparison meter is available these two resistors can be selected from the available stock, the actual value being unimportant. A good compromise would be to use 5% tolerance for these two resistors, and to use the one of higher value as  $R_9$ .

Apart from the use of 5% tolerance for  $R_8$  and  $R_9$ , the above precautions are unnecessary in amplifiers incorporating the balance control,  $R_{39}$ .

#### NEW MEMORY CIRCUIT

THIS uses a multi-mode oscillator such that when about five cycles of one of the modes is injected it continues to oscillate in that mode. The theoretical conditions for stable oscillators of this type are discussed by L. R. de Gopegui in *Revista de Ciencia Aplicada*, Vol. 10, No. 5 (in Spanish). Practical oscillators include a quartz delay line with 350 modes. When more than nine modes are available operation can be in the decimal system. An experimental travelling wave tube model operating at 34 kMc/s offers a much reduced "writing in" time.

# Measuring and Test Gear

## NOTABLE DESIGNS AT RECENT EXHIBITIONS

**T**HIS review covers instruments shown at the recent Physical Society, R.E.C.M.F. and I.E.A. exhibitions.

**Current and Voltage Meters.**—In ordinary moving-coil meters, as distinct from laboratory galvanometers, double-pivot suspensions are usually employed; but some models shown by Turner are suspended by strips, and are claimed to be actually more robust than the normal type.

Tinsley showed miniature versions of laboratory instruments such as potentiometers and galvanometers. Sizes have been reduced by a factor of four or more without any sacrifice in accuracy. For example, the mirror galvanometer (5285) is only  $5\frac{1}{4}$  in  $\times$   $4\frac{1}{2}$  in  $\times$   $2\frac{1}{2}$  in.

Nalder and Thompson demonstrated some interesting subsidiary techniques, such as coupling an additional moving coil so as to operate a contact system at a particular angular velocity of the coil. One use of this is to lock a meter at a particular part of a waveform so that it can be read at leisure.

**Frequency Meters.**—A simple frequency meter (5 c/s-30 kc/s) introduced by B.T.H. uses a saturating transistor amplifier to charge and discharge a condenser on each cycle of the input voltage. The mean current is proportional to the frequency, and independent of the waveform, provided that the signal passes through zero only twice in each cycle.

**Digital Techniques.**—By using a crystal-controlled oscillator and digital counting techniques, intervals can be timed to an accuracy of one oscillation. If a series of input signals are also counted their frequency can be determined. Instruments using these principles were shown by Racal and Cintel.

For counting very high frequencies between 1 Mc/s and 30 Mc/s a frequency converter unit SA33 was shown by Racal. The input signal is mixed with the output of an oscillator, whose frequency can be varied from 41.5 to 69.5 Mc/s, to give an output at the first i.f. of  $40 \pm 0.5$  Mc/s. At the same time the output of the variable frequency oscillator is mixed with the harmonics (1st to 32nd) of a 1-Mc/s crystal oscillator

to give an output at the second i.f. of  $37.5 \pm 0.15$  Mc/s. The outputs from the first and second i.f.'s are mixed to give signals in the range of 2 to 3 Mc/s. These are mixed with a 3 Mc/s signal to give finally frequencies in the range 0 to 1 Mc/s. These signals may then be registered on a Racal SA21 counter. The advantages of this complicated mixing arrangement are that any drift of the variable frequency oscillator is cancelled out when the first and second i.f.'s are mixed, and also that no switching is involved.

Digital techniques were also used in a transistor voltmeter exhibited by the Radar Research Establishment. Starting from the most significant digit, voltages proportional to successive digits are set up by trial

ranges of 0 to 5, 50 or 500 oersteds are suitable for the measurement of fields due to television or particle accelerator focusing magnets, or to transformers (strays).

**Resistance Measurements.**—Low resistances between  $5 \times 10^{-8}$  and 1,200 ohms can be measured by the Electronic Instruments 47A milliohmmeter. The voltage developed across the component by a mains-frequency supply is amplified using a "starved" amplifier. A phase-sensitive rectifier circuit reduces errors due to any series reactance smaller than the resistance. At mains frequency it is unlikely that any such reactance will be as large as this. A calibration check is included.

A decade Wheatstone bridge by

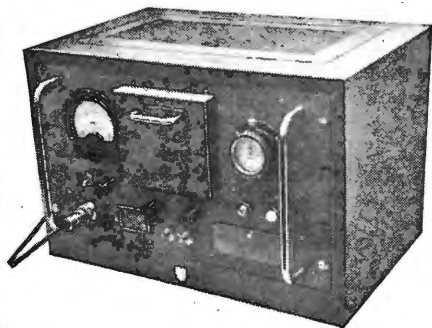

Ekco N535 High Resistance Meter.

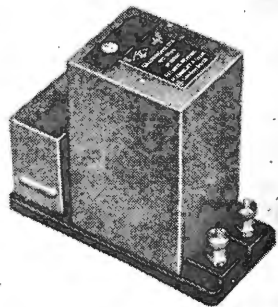

Tinsley 5285 Miniature Mirror Galvanometer.

and error. Comparison with the inputs voltage determines whether each trial digit is accepted or rejected.

**Magnetic Measurements.**—A magnetometer based on gyromagnetic coupling in ferrites was shown by Newport Instruments. A ferrite ring in a probe is excited to saturation by a.c. in a toroidal winding. Any external magnetic field produces a voltage across a solenoid wound at right angles to the exciting winding. This voltage is proportional to the external field and at a frequency twice the exciting frequency. A thermometer in the probe enables the necessary corrections for temperature to be made. The three

Cintel can measure resistances from  $0.1 \Omega$  to  $100 M\Omega$ , and also indicate whether a resistance is within a pre-set tolerance (7 ranges from  $\pm 1\%$  to  $\pm 25\%$ ).

The Ekco N535 measures high resistances from 1 to  $10^8 M\Omega$  by using an electrically operated stop-watch to find the time taken to charge a known capacitance to a known voltage through the resistance to be measured.

**Component Bridges**—A wide range (at least  $5 \times 10^{11}$  to 1 in any given quantity) and the possibility of *in situ* measurement are offered in the new Wayne-Kerr B521 LCR bridge. The unknown and standard impedances are transformer fed in

opposition from the mains frequency source so that when the two impedances are equal there is no output from the detector (also transformer coupled). This transformer isolation of the impedance permits a three-terminal facility in that the impedance between two points can be measured regardless of any other impedances between these points and a third point. The other impedances can be arranged to shunt the input and output transformers, and this merely reduces the bridge sensitivity. Resistance and reactance are measurable simultaneously by two balance controls. Some four-terminal measurements are also possible. One of these enables the resistances of leads, transformer windings and switch contacts to be almost entirely eliminated when low resistances and inductors are being measured.

The new Muirhead D897A bridge measures resistances from  $10^{-3}\Omega$  to  $1\text{M}\Omega$ , capacitances from  $1\text{pF}$  to  $100\mu\text{F}$ , inductances from  $1\mu\text{H}$  to  $1,000\text{H}$ , capacity dissipation factors from 0 to 1.2, and  $Q$ 's from 0 to 60; the reactive measurements being made at 1,000 c/s.

Two neons indicate by equal brightness the balance point in the Nash and Thompson small RC bridge. Resistances from  $5\Omega$  to  $500\text{M}\Omega$  and capacitances from  $5\text{pF}$  to  $500\mu\text{F}$  (3 ranges each) at mains frequency can be measured. Comparison of components ( $-30\%$  to  $+45\%$ ) in somewhat narrower ranges is also possible.

**Transistor Test Sets**—There are now several of these available. They range from the very simple S.T.C. 74163A, which measures the current gain of p-n-p transistors in the common emitter configuration at a particular working point (2 mA emitter current,  $-1.5\text{V}$  collector volts), through the more elaborate Mullard L264 which measures current gain, d.c. collector current for zero base current and collector turnover voltage, to the complex Airmec 236 and Siemens-Ediswan experimental model for all parameters of p-n-p transistors, and the Microcell 107 for both p-n-p and n-p-n transistors at various working points. The more elaborate types generally use small signal a.f. measurements. A Radio Research station exhibit showed the measurement of short-circuit current gain from 1 to  $105\text{Mc/s}$ . The Bonochord test set has the unusual additional facility of enabling a noise comparison to be made at various operating conditions.

**Valve Voltmeters**—New valve voltmeters measuring down to about  $0.5\text{mV}$  between about 5 c/s and 500 c/s were shown by Dawe and by Nash and Thompson. The Dawe (612) uses a square-law detector to give a true r.m.s. reading regardless of waveform. The upper frequency limit is extended to  $10\text{Mc/s}$  in the Burndept BE239. Another less sensitive ( $20\text{mV}$ ) Nash and Thompson model measures both d.c. and a.c. voltages up to  $500\text{Mc/s}$ . Improvements in the upper frequency limit are offered in the latest versions of the Airmec (217) and B.P.L. (VM853B) valve voltmeters; in the latter case to  $1,000\text{Mc/s}$ .

**Generators (Continuous)**—Proceeding from small to large quantities we start with the Short and Harland low-frequency decade oscillator ( $0.01$  to  $110\text{c/s}$ ) for servo testing. Oscillations may be started either exactly at zero or at maximum of the sine wave; when switched off the amplitude decays exponentially to zero. The total harmonic and d.c. contents are less than  $0.2\%$  and  $100$  microvolts respectively. Up to  $20$  volts peak and  $15\text{mA}$  are available.

A versatile oscillator shown by Furzehill (G435) can provide sine or square waves at frequencies between  $25\text{c/s}$  and  $250\text{kc/s}$ . Fixed frequency decade RC oscillators are used, but a calibrated (accuracy  $\pm 2\%$ ) variable incremental RC oscillator adds continuous coverage. Internal calibration frequencies of  $1\text{kc/s}$  and  $10\text{kc/s}$  with their harmonics (accurate to  $\pm 0.01\%$ ) are provided.  $1\mu\text{-sec}$  (rise time less than  $0.02\mu\text{sec}$ ) pulses at p.r.f.'s of  $1,000$ ,  $1,500$  or  $2,000/\text{sec}$  are also available.

The Muirhead D650B decade oscillator covers frequencies from 1 to  $11,110\text{c/s}$  in  $1\text{c/s}$  steps and 10 to  $111,100\text{c/s}$  in  $10\text{c/s}$  steps. On the lower range a continuously variable frequency increment of 1 to  $2\text{c/s}$  is also available.

Elliott were showing a continuous sweep frequency oscillator for working between any two frequencies in the range  $20\text{c/s}$  to  $5,000\text{c/s}$  or  $200\text{c/s}$  to  $50,000\text{c/s}$  at any rate up to 5 octaves per minute. A Wien bridge oscillator is used, the resistive elements being thermistors. The resistances of the thermistors, and hence the frequency of oscillation,

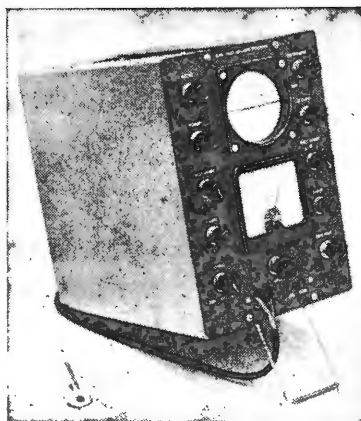

E.M.I. WM4 Miniature Measuring Oscilloscope

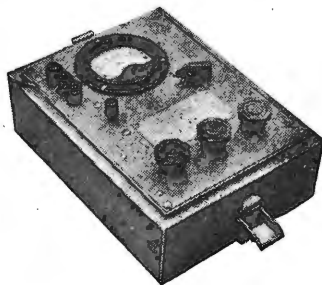

S.T.C. 74163A Transistor Test Set.

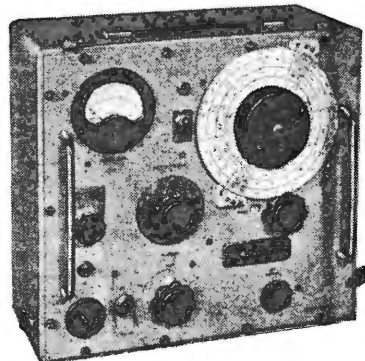

Advance DIP/2 v.h.f. Signal Generator.

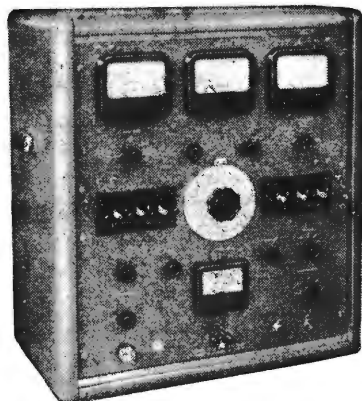

Microcell 107 Transistor Test Set.



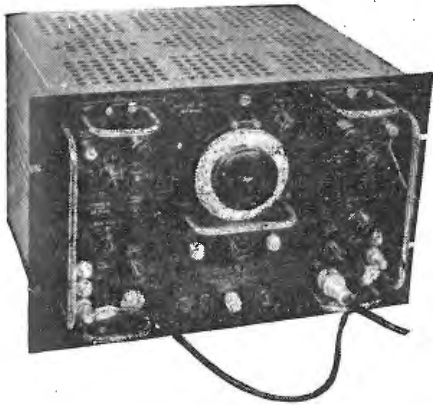

Left: Fleming  
1147B Two  
Pulse Genera-  
tor.

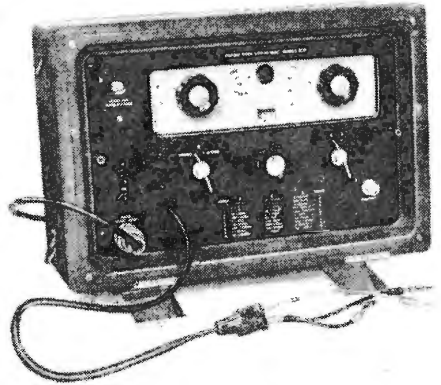

Wayne Kerr  
B521 Component  
Bridge.

are varied by varying the direct current through them. Second harmonic distortion is less than 1%, and the sweep rate of the logarithm of the frequency is fairly constant over most of the frequency range.

Constancy of the output level to within  $\pm 0.1$  dB is a feature of the Marconi TF1099 sweep frequency generator for alignment of television equipment. An oscillator is swept over a maximum range of 60 to 80 Mc/s using a ferrite reactor driven by a variable fraction of the time-base sawtooth. The final swept signal (variable up to 20 Mc/s) is obtained by frequency changing with a 60-Mc/s local oscillator. Differential response measurements to within 0.01 dB are also possible.

The Decca MW76 is basically a b.f.o. with a range of 10 to 200 Mc/s in one band, obtained by beating two X-band klystrons together. Simultaneous or separate mechanical sweeping up to  $\pm 50$  Mc/s, and pulse modulation are possible. The wide frequency range facilitates rapid examination of responses.

The Advance 63 a.m./f.m. signal generator covers from 7.5 Mc/s to 230 Mc/s to a calibrated accuracy of  $\pm 1\%$  which may be checked every 5 Mc/s to  $\pm 0.01\%$  using an internal crystal calibrator. Amplitude modulation of 10% or 30% at 1,000 c/s, and frequency modulation also at 1,000 c/s with a deviation of  $\pm 60$  kc/s, or at the mains frequency with a variable deviation up to  $\pm 150$  kc/s, are available. The new Advance D1P/2 is a special version of the D1/D for the alignment of narrow band receivers in the range 2 to 190 Mc/s.

The Marconi a.m./f.m. signal generator TF1064 covers 68 to 174 Mc/s and 450 to 470 Mc/s together with a choice of five crystal-controlled, commonly used i.f. values between 450 kc/s and

12.5 Mc/s. Amplitude or frequency modulation at 1,000 c/s is available; the a.m. depth is 20%, and alternative f.m. deviations of 5 kc/s and 25 kc/s can be obtained. A  $\pm 100$  kc/s incremental tuning system is incorporated for bandwidth measurements.

Waveforms, Ltd., were showing two television pattern signal generators. In both of these simultaneous sound and vision independently adjustable in frequency are available on Bands I and III. In the W90A any one of the three line and three frame modulated patterns may be combined. The master frequency may be unlocked from the mains for hum checking, and the output voltage ( $1 \mu\text{V}$  to 100 mV r.m.s. on sound or vision) is calibrated to  $\pm 0.5\%$ . In the portable 405D four basic modulated patterns are available.

**Generators (Pulse).**—Wide range pulse generators were shown by Wayne Kerr (X321) and Ericsson (104A). The range of pulse lengths in the Ericsson is 4 to 500  $\mu\text{sec}$  at p.r.f.'s from 10 c/s to 100 kc/s, both continuous. In the Wayne Kerr sine and square wave oscillations at frequencies between 50 c/s and 50 kc/s can also be obtained.

A number of pulse generators designed for nuclear equipment testing were also shown. The Fleming Radio (Developments), Ltd., 1147B provides two output pulses of rise time about 8  $\mu\text{sec}$  and widths of 0.05, 0.25 or 1  $\mu\text{sec}$ . Two crystal-controlled oscillators trigger the pulses at p.r.f.'s of 1 kc/s, 10 kc/s or 50 kc/s; or alternatively both pulses may be triggered by the same oscillator. The two oscillators differ in frequency by about 1 part in  $10^4$  so that when the pulses are separately triggered they drift slowly in and out of coincidence. This mode of operation is useful for

measuring the resolving time of coincidence units. The Fleming 1478A is a crystal-controlled pulse generator designed to give an accurate source of 2- $\mu\text{sec}$  pulses at p.r.f.'s from 100 kc/s down to 1 c/s in decades. A  $\div 2$  or  $\times 4$  switch gives additional frequencies.

**Transmitter and Receiver Test Equipment.**—A number of specialized items in this field were shown. The Marconi test modulator HQ72 and discriminator HQ73 are designed for distortion measurements on v.h.f. (60-230 Mc/s), multichannel transmitting and receiving equipment. The overall frequency response of the two units is within  $\pm 0.25$  dB from 10 kc/s to 200 kc/s. The distortion products are lower than  $-55$  and  $-60$  dB relative to the fundamental for the second and third harmonics respectively for a deviation of  $\pm 300$  kc/s in the range 10 to 100 kc/s. The Marconi TF1065 test set can measure a.f. (250 c/s to 10 kc/s) and r.f. (50 kc/s to 500 Mc/s) powers, and f.m. deviations. Shunts are also provided internally to convert the 50- $\mu\text{A}$  f.s.d. panel meter into a 7-range d.c. voltmeter/ammeter. Amplitude modulations up to 100 per cent and f.m. deviations up to  $\pm 100$  kc/s at modulation frequencies between 30 kc/s and 15 kc/s can be measured to better than  $\pm 5\%$  in the Airmec 210. The carrier frequency range is 2.25 to 300 Mc/s.

**Oscilloscopes.**—A miniature (12 $\frac{1}{2}$  in  $\times$  9 in  $\times$  7 in) oscilloscope for television servicing shown by Waveforms, Ltd. (the 302) has a response which is 3 dB down at 6 Mc/s, the maximum sensitivity being 0.1 volts/cm. Time-base recurrence frequencies from 0.5 c/s to 66 kc/s are available. The Metropolitan-Vickers miniature oscilloscope is available for use with a.c. mains (CT52) or 28 volts d.c. (CT84).

The E.M.I. miniature oscilloscope

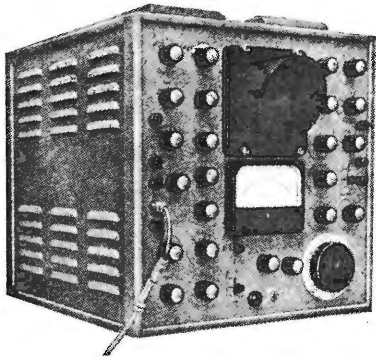

S.T.C. 74169A Television Measuring Oscilloscope.

WM4 (10½ in × 9½ in × 6½ in) incorporates a multi-range a.c./d.c. voltmeter which gives a direct measurement (independent of amplifier gain) on the displayed waveform, to within ±5%. The direct-coupled Y-amplifier has a sensitivity range from 0.2 volts/cm (3 dB down at 1.5 Mc/s) to 4 volts/cm (3 dB down at 3.5 Mc/s). Time base frequencies from 7 c/s to 120 kc/s can be obtained.

The Marconi TF1159 has a 17-inch rectangular c.r.t. for detailed investigation (or lecture demonstration purposes) of waveforms between 15 c/s and 20 kc/s. Time-base repetition frequencies from 15 c/s to 5 kc/s are available.

Three new models were shown by Cossor. The 1042A radar oscilloscope has a calibrated triggered time-base spot velocity variable from 0.5 μsec/cm to 15 msec/cm. The d.c. Y-amplifier has a response 3 dB down at 5 Mc/s, the maximum sensitivity being 1 volt/cm. An ancillary amplifier gives a sensitivity up to 10 mV/cm for l.f. signals, the response being 3 dB down at 4 kc/s. The 1065 is designed for pulse measurement. The d.c. Y-amplifier is 3 dB down at 11 Mc/s the maximum sensitivity being 0.25 volts/cm. The rise time and overshoot are less than 40 μsec and 5% respectively. The time base gives spot velocities from 0.2 μsec/cm to 25 msec/cm. X and Y shift controls calibrated to within ±10% are available. More accurate time measurements can be obtained from intensity modulation dots produced to an accuracy of ±5% by a 25 Mc/s oscillator. The 1071K double beam d.c. oscilloscope is an addition to the Cossor range of kit models.

Both time and amplitude measurements to within ±2% are possible in the prototype Solartron CD643. The response is from d.c. to 15 Mc/s (3 dB down), the maximum sensitivity being 75 mV/cm. Y-measure-

ment is by calibrated shift control. The time-base range is from 50 μsec/cm to 100 msec/cm; and measurement is by marker pips at 1 μsec, 100 μsec and 10 msec intervals, or by "bright-up" waveform starting at any point on the trace and of any duration from 10 μsec to 100 msec.

Beam switching, by chopping at l.f. and alternate sweep switching at h.f., is used in the prototype Solartron CD711. The two identical d.c. Y-amplifiers are 3 dB down at 7 Mc/s, the maximum sensitivity being 100 mV/cm. An a.c. pre-amplifier can increase the sensitivity up to 3 mV/cm for a response 3 dB down at 2.5 c/s and 200 kc/s. Amplitude measurement to ±5% by calibrated shift control is possible on either channel. The time base has a calibrated (±5%) sweep rate from 0.3 μsec/cm to 0.3 sec/cm, and an uncalibrated range from 0.3 sec/cm to 3 sec/cm.

Four independent channels and tubes are provided in the Airmec 249. The identical Y-amplifiers have a sensitivity range from 10 mV/cm (response 30 c/s to 100 kc/s) to 3V/cm (response d.c. to 3 Mc/s). Time base speeds from 0.33 μsec/cm to 33 msec/cm are available. Calibrated shift controls on both X and Y deflections are provided. Southern Instruments were showing a flexible panel unit system for building up multi-channel oscilloscopes. The amplifiers (with monitor tube for each channel) and power supplies are entirely separated from the actual tube displays.

An elaborate oscilloscope (74169A) shown by S.T.C. comprises pulse amplitude and time measuring equipment for use on television communication systems. Frame and line slope, together with picture content

and synchronizing pulse compression can be checked.

Two oscilloscopes were seen with spiral time bases, which permit a longer recording time than usual for the same accuracy. The Nagard exhibit used a normal c.r.t. and the rotation rate was 1 c/s. By contrast the U.K. Atomic Energy Authority showed a crystal-controlled 50 kc/s time base, and a special c.r.t.

**Spectrum Analysers.**—The components of a signal in the range 40 c/s to 25 kc/s are automatically plotted as vertical deflections on a c.r.t. in the E.M.I. 1950/2, at sweep rates between 1 c/s and 2 c/s. The 4-position selectivity covers a range of 50 c/s to 500 c/s: the response being at least 40 dB down outside the pass band.

The Marconi TF455E wave analyser can be tuned between 20c/s and 16kc/s. The input signal is frequency-changed in a balanced-ring modulator to give an i.f. of 50 kc/s. A double-crystal filter then gives a selectivity of 4 c/s (response 40 dB down 30 c/s off tune). An a.m. detector stage usable up to 80% modulation between 100 kc/s and 500 Mc/s permits envelope measurements on r.f. signals. Direct measurements on r.f. signals are possible on the more elaborate Marconi OA1094. This can be tuned between 3 and 30 Mc/s, and has a sweep width variable from a few c/s up to 30 kc/s. A triple superhet circuit and crystal filters give alternative 3 dB bandwidths of 6, 30 and 150 c/s. Six sweep durations from 0.1 to 30 sec are available.

A v.h.f. analyser for the range 25 to 140 Mc/s shown by the P.O. Engineering Department is designed for broad-band signals, the maximum sweep width being 50% of the centre frequency and the useful minimum about 1 Mc/s. Alternative 3 dB bandwidths of 7 and 35 kc/s are available. The frequency scan is obtained by varying the polarization of a ferrite-cored inductor in the oscillator.

The Decca Radar S-band test set MW69S incorporates a measuring oscilloscope and spectrum analyser. This latter uses a CV2116 klystron to cover frequencies between 2700 and 3050 Mc/s with a sweep range up to 25 Mc/s. The i.f. bandwidth is 100 kc/s. An X-band microwave spectrometer shown by the Radar Research Establishment uses a tuned cavity which is mechanically swept at 50 c/s by vibrating the piston at one end, that at the other providing tuning over a 10% band. The high resolution of 200 kc/s is achieved.

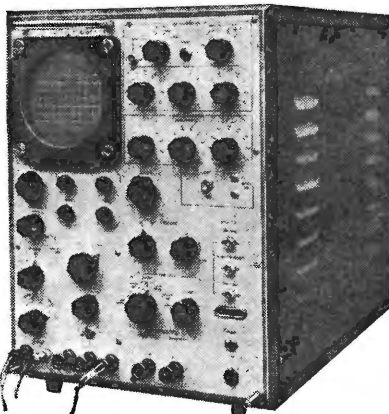

Solartron CD643 Measuring Oscilloscope.



# Colour TV in U.S.A. By C. G. MAYER,\* O.B.E., M.I.E.E.

## RECORD OF ACHIEVEMENT SO FAR

**I**N the U.S. colour television came at a time when black-and-white television was booming, and hence what might have been regarded as a normal rate of development has tended to look slow and has even, in some quarters, been labelled as "a failure." It is hoped that this factual status report will bring the matter into perspective and show that colour is making good progress.

**Sets Sold.** During the first quarter of 1957 the number of installations made was more than double that of the corresponding period of 1956. The number of dealers now selling colour sets is more than twice what it was in 1956, and they experience no difficulty in handling the sets with their available personnel. About 150,000 sets have been sold altogether since the large-screen models were introduced in the autumn of 1955. Demonstrations in homes are resulting in sales in as many as three out of four cases in some areas—proving that those who see colour TV like it.

**Programmes.** Colour set buying has been stimulated by the ever-expanding schedule of network colour programming. The National Broadcasting Company has increased its evening colour schedule by 500 per cent over the last year. The networks are now offering close to 100 hours of colour every month, with many major programmes being transmitted during prime time. During the month of May, as a special colour drive, viewers in the Mid-West area had a chance to see 230 hours of colour programming, with an average of 7½ hours a day. More than half of America's 490 TV stations are now able to broadcast in colour, and about 96 per cent of all television homes lie within range of colour programmes. The majority of these stations rely on network programming. NBC and CBS each have about 140 affiliated stations equipped and transmitting network colour, which number represents an increase of about 30% compared with a year ago. In addition over 100 of these stations are equipped for some form of local colour broadcasting (slide and film) and 35 stations have colour cameras to originate live colour programmes. Viewers can tune-in to as much as three hours of colour on some evenings, with at least one major colour transmission every night of the week.

**Receiver Prices.** The price of colour receivers is usually cited as one of the main reasons for the slower rate of growth of colour television, but this is not borne out by the facts. A table model set can be bought today for \$495, which compares quite favourably with the prices of black-and-white sets at the time when large volume sales started to grow. Because banks are willing to extend easier credit terms for the purchase of a colour set, the payments work out almost the same as for a black-and-white set—about 50 cents per day. According to a study by a Philadelphia bank, 90% of the present colour set buyers are people with a salary range of \$80 to \$90 per week. This indicates that colour is definitely not priced beyond the average family's reach. Relating these figures to British incomes in terms of cost of living, it means that colour sets are being bought by people who in this country would be earning £13 to £15 per week.

There has already been a price reduction of fully 50% in the last 2½ years—half the period that occurred for black-and-white sets. Colour sets are more expensive for two reasons. First, the colour picture tube is more costly, and second, the set requires additional and more precise circuitry to deal with the colour signals. The only picture tube so far in mass production is the three-gun shadow mask tube. Despite reports that cheaper picture tubes are nearing development, RCA tube engineers see nothing even on the horizon which would make the present shadow mask tube obsolete. There are thus

*Criticisms on economic and technical grounds of colour television, as we know it today, have been freely ventilated in this journal. In this article arguments are put forward in refutation of some widely held opinions.*

no prospects in sight for further price reductions. In fact, the outlook generally is for price increases due to the rising cost of labour and materials.

**Adjustment and Servicing.** With regard to servicing of colour sets, it can be only malicious humour and a lively imagination which refers to the need for an M.I.T. engineer to adjust and service every set installed. A recent survey shows nine out of every ten colour set owners fully satisfied with the performance and effectiveness of their sets. Less than 3% indicated any dissatisfaction because of too many service calls. Statistics show that in the first three months, a black-and-white set requires an average of two service calls, while for colour sets the average has worked out at 2½ calls, including in both cases the initial installation call. Thus there is no sensible difference in installing and servicing black-and-white or colour sets. Actually the cost of maintenance per dollar invested is lower for colour sets than for black-and-white. The comprehensive service charge in the U.K. for a 17in black-and-white set is about £17 per year, i.e., approximately 20% of the initial cost of the receiver. In the U.S. the comprehensive service charge for a 21in colour set is \$99.50, again 20% of the initial cost. Expert colour servicing is available, since during the past three years more than 105,000 service technicians have attended "colour clinics" conducted by a travelling team of RCA service training personnel in over 250 cities and towns.

There are no difficulties in adjusting the two extra controls of a modern colour set. The set is tuned in the usual way to give a good black-and-white picture. It then requires only a simple adjustment of the "colour" knob to obtain the degree of colour desired. Adjustment of the "hue" knob produces the shading and flesh tones which are most pleasing to the eye. That is all there is to it, and in many households small children have learned to adjust the sets without difficulty.

**The Future.** Within the technical standards adopted by the Federal Communications Commission any manufacturer can design a colour TV system. However, the only such system in use in the U.S. today is the compatible colour system developed by RCA. It has been suggested by people who should know better that this system was planned basically for use with the 3-gun shadow mask tube. The fact is that any other type of tube could be used if it were efficient and economical enough to do the job, but there is no indication of any such tubes being ready for production for at least several years. Neither has there been any evidence that such tubes would simplify set design. When and if they do become available, there will be no need to change the form of the signal. This was recommended by the N.T.S.C., and took into account the vital need for radio spectrum conservation by making more complete use of the existing TV channel bandwidth to add the desired colour information.

In America colour TV is proving that it can provide a greater and more interesting service to the public and develop into a profitable business for broadcasters, manufacturers, distributors and dealers, and a rewarding medium for advertisers. Nothing can stop the continued progress of colour TV, and there is surely no longer any basis for the "colour blindness" which seems to prevail in Britain today.

\*RCA Great Britain Ltd.

# Superconductivity

A Cold Outlook for Computers

By "CATHODE RAY"

**I**N the issue before last, while discussing the time constants of inductive circuits, I mentioned that the only way an inductor could be freed from resistance was by reducing its temperature to nearly  $273^{\circ}\text{C}$  below zero, "which" I went on to remark "is inconvenient." At the time, this was intended to be one of those masterly understatements which are among the few things for which we British are still famed. It is a striking example of the speed with which applied science moves on that before the words were even set up in type they had begun to seem almost an exaggeration. I had not bargained for this year's Physical Society's Exhibition, at which it was demonstrated to all and sundry that not only is liquid nitrogen handled as nonchalantly as water but even liquid helium can be transferred from store to a suitable flask as easily as beer from a barrel. According to information freely distributed, the N.P.L. is prepared to lay on supplies of liquid helium by the litre to anyone interested. It would hardly surprise me if, by the time these words were in print, someone had got on to the idea of avoiding duplication of transport, by arranging for it to be delivered with the milk.

The point, however, is not so much that now we shall all be able to amuse our guests by making a little bar magnet jump up and float over a lead dish without support, for I suspect—though nothing so sordid was actually mentioned in connection with the N.P.L. offer—that this is not yet part of the Health Service, and money may have to be paid. What probably has more long-term significance is the news about the cryotron, given in a technical note on p. 232 of the May issue.

Even the proverbial schoolboy will have no difficulty in interpreting "tron" as "a valve, especially one of the fancier kinds." Whatever objections the ancient Greeks might be inclined to lodge against this, they would surely have to admit that "cryo" (from Krios=cold) was apt. For the cryotron can't begin to work until the temperature is in the region of  $-269^{\circ}\text{C}$ . This is so far outside the realm of normal experience for most of us that we may need a little time to get used to the idea. So let us run over the main points about temperature, and low temperature in particular.

In general conversation no clear distinction is drawn between heat and temperature. But in scientific usage they are analogous to charge and voltage, or quantity of water and level. Heat is a form of energy, and if it is imparted to a body, the temperature of that body rises. The amount it rises depends on the thermal capacity of the body, just as the voltage set up across a capacitor by putting a given charge into it depends on the capacitance.

Increase of temperature is recognized by various effects such as expansion of the body and its change of state from solid to liquid and from liquid to gas, and often by chemical changes. Because the body—any body—consists of atoms, these effects are all due to increasing the energy of the atoms. In

general, the energy imparted to atoms is stored as movement and arrangement of the parts—the nucleus and surrounding electrons. The highest energy positions of the electrons are those farthest from the nucleus, and the more energetic the movements the greater the tendency for the atoms to fly apart. Without going into details, one can imagine how these tendencies in the invisibly small structure of a material may well account for the various things we can see happening to it in bulk.

## Absolute Zero Temperature

Conversely, withdrawing heat reduces the energy of the atoms, so it is natural to suppose that if all the energy were withdrawn the temperature could go no lower, and that point might aptly be called "absolute zero." Presumably everything would be solid and there would be no chemical activity, and therefore no possibility of life. A long time ago it was decided from scientific evidence that this absolute zero was at  $-273^{\circ}$  ( $-273.16^{\circ}$  to be more exact) on the centigrade (or Celsius) scale ( $= -460^{\circ}\text{F}$ ). This is the obvious logical zero point for a scientific temperature scale. For instance,

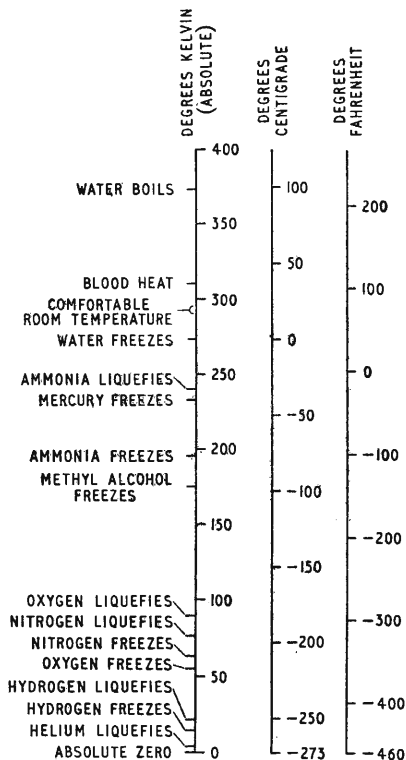

Fig. 1. Comparison of three temperature scales, showing some of the more important "milestones."

internally generated circuit noise is proportional to the temperature above absolute zero, or (as it is called) absolute temperature. It is expressed in degrees the same size as centigrade degrees, so to convert a temperature on the centigrade scale to the absolute scale just add 273°. To distinguish temperatures reckoned from absolute zero from those reckoned from centigrade zero the letter K (for Kelvin) is substituted for C. So ice melts at 273°K and water boils at 373°K (at normal atmospheric pressure). Fig. 1 shows some other points on the temperature scales.

Since absolute zero was established, there has been intense competition among scientists to get there. Or, rather, as near it as possible; for, like a perfect vacuum, it can be approached but not reached. I don't know the very latest figure, but 0.001°K was attained a year or two ago, and 0.000001°K was reckoned to be practicable in the not too distant future. Looking at Fig. 1, and thinking that such an elaborate machine as the domestic "fridge" is needed to drop the very little way from room temperature to just below water freezing point, you may well wonder how such an enormous depth of temperature is reached. Clearly, the lower one goes the more difficult it gets, for the surroundings become relatively hotter. Solid air in an ordinary room is like the proverbial snowflake hell.

The full story, of course, is a long one; but the basis for most of it is the fact that when a gas expands it does work and therefore loses energy, so its temperature drops. This can be felt when one lets down the pressure of an over-inflated tyre by opening the valve. The coldness of the blast of air is the converse of the warmth the pump acquires when it is used to compress air into the tyre.

By compressing air to something of the order of 200 atmospheres, cooling it by air that has already been greatly cooled by expansion, and then allowing the cooled high-pressure air to expand, a proportion is liquefied. Liquid air can then be used to bring hydrogen to the point where it can be liquefied by a similar technique; and hydrogen in turn can be used as the starting point for liquefying helium. Or the whole thing may be done in two stages. It is now quite commercial.

At the liquid helium stage everything else is solid, so to go lower an entirely different technique is necessary. The principle employed is that when certain magnetizable salts (such as iron ammonium alum) are magnetized they generate heat. This is removed by contact with liquid helium; contact is then broken, and the magnetizing field is cut off. Heat is used up in the process, and as the salt cannot get it from its surroundings it drops in temperature.

## Unexpected Behaviour

One of the most interesting things about exploration of low temperatures has been seeing whether things turned out as expected. It was expected that one by one all gases would liquefy and then solidify, and that was just what happened. (Except that in order to solidify helium it is necessary to apply at least 25 atmospheres pressure.) The thing we are concerned about just now, however, is electrical resistance, and from the start it was realized that that would not be straightforward. Whereas the

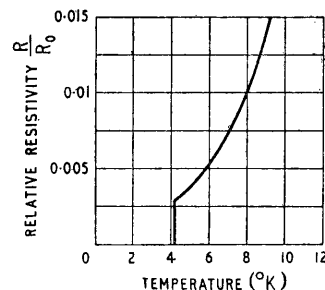
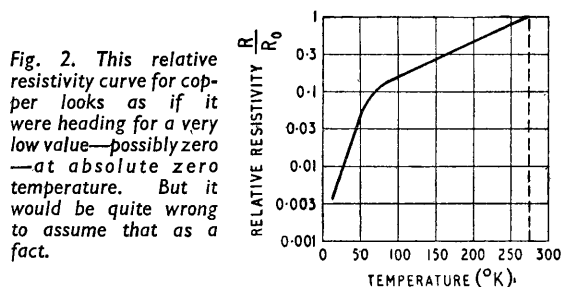

Fig. 3. This low-temperature end of the resistivity curve for mercury also looks (down to 5°K) as if it were heading for zero at zero temperature, but in fact it drops straight there at 4.15°K.

low resistance of metals becomes even lower as they are made colder, the moderate resistance of carbon and the higher resistances of semi-conductors and insulators increase. Various theories were put forward to account for this, and had to be modified or abandoned as the curves were plotted to lower and lower temperatures.

Even metals showed strange anomalies; copper for example (Fig. 2) decreases steadily to about one-tenth of its resistance at 0°C; then at about 50°K the rate of fall-off greatly increases, and at 15°K it is down to about one three-hundredth. All the curves for metals, however, seemed down to that point to be heading steadily towards some very small value—possibly even zero—at 0°K. An experimenter, baffled in his efforts to lower the temperature any farther, might have been tempted to dot in his curves accordingly. There was no theoretical reason for expecting otherwise.

But in 1911 Kamerlingh Onnes, obtaining experimental data on the low-temperature resistance of mercury wire, made the astonishing discovery that at 4.15°K the resistance suddenly disappeared altogether, as in Fig. 3. He thereby provided a classic example of how wrong one can be to guess the last little bit.

This state of having no resistance is called superconductivity, and the temperature at which it comes into force is the transition temperature. The transition temperatures of 21 metals and numerous alloys have been found, extending from about 17°K downwards. One might reasonably expect the most conductive metals—silver, copper and gold—to be among the first to turn superconductive. So far from fulfilling this expectation, however, not one of them has become superconductive at all, even down at 0.05°K. On the contrary, with almost human perversity the curve for copper (Fig. 2) suddenly reverses and ends with a turn-up. Some other metals level off to a constant low resistance.

These are only a few of many examples of how

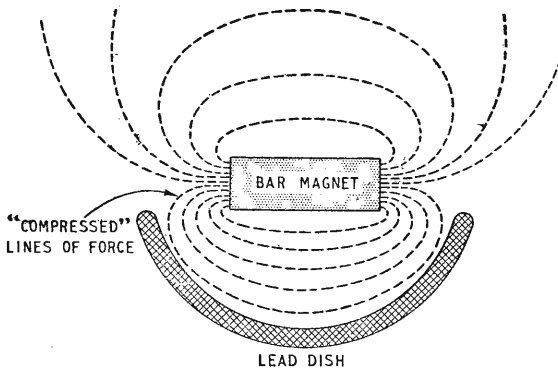

Fig. 4. The idea of lines of force being elastic transversely helps one to visualize why a bar magnet floats above a superconducting lead bowl, which has zero magnetic permeability.

everything about electrical resistance seems to go completely haywire at very low temperatures. It is difficult enough to make atomic theory cover all the facts about resistance even at other temperatures. A very few specialists claim to have low-temperature resistance theories\*, but I must ask to be excused from expounding them. Most people, I am sure, will be prepared to let theories pass, so long as practical benefits are obtainable. Before going on to them, however, we ought to consider some of the implications of zero resistance.

My reference to superconductivity in the May issue was by way of pointing out that although the charge could be retained on a capacitor while switching it from one circuit to another—by simply open-circuiting it—the current couldn't be kept flowing for long in an inductor at ordinary temperatures by short-circuiting it (which is the "dual" counterpart of the open-circuited capacitor), because that didn't reduce its resistance to anything like zero. But at liquid helium temperatures it is commonplace. The best-known thing about Onnes was that he kept current flowing in a lead ring without any e.m.f., not just for the time required to switch it, but for days. In a more recent experiment at the Massachusetts Institute of Technology a current of hundreds of amps in such a ring was still going strong after two years! Since the time constant of an inductive circuit is  $L/R$ , making  $R=0$  raises it to infinity.

When considering skin effect in the November 1953 issue we reached the conclusion that the tendency for current to flow at the surface rather than the core of a conductor shows itself at a lower frequency the lower the resistance of the conductor. The logical conclusion is that with zero resistance skin effect appears at zero frequency. And that is in fact so. Even d.c. is found to be all within a few millionths of a centimetre of the surface. It follows too that high-frequency currents in superconductors are subject to super-skin-effect. Notwithstanding this, at 10 Mc/s the resistance still seems to be zero. But at 1,000 Mc/s there is appreciable resistance.

Another feature of superconductivity, known as the Meissner effect, is that the metal becomes per-

fectly diamagnetic; that is to say its permeability is zero, so no magnetic flux can pass through it. Just as a magnet attracts substances which have a permeability greater than 1 and which therefore increase the total magnetic flux, it repels substances with a permeability less than 1, which unless removed would reduce the amount of flux. Hence the success of the floating magnet experiment. Those who find the idea of elastic lines of force helpful will no doubt picture them forcing the magnet up from the superconductor, as in Fig. 4.

This absence of magnetic flux in a superconductor ties up with the absence of current in its interior. In an ordinary conductor, the interior parts of the current give rise to some magnetic flux within the conductor.

A neat experiment for demonstrating the effect is to wind a copper coil toroidally around a lead cylinder, as in Fig. 5. Above the transition temperature for lead, current passed through the coil sets up magnetic flux around the cylinder; in other words, the coil is inductive, and a galvanometer connected in a secondary winding shows the usual inductive "kick" when current is switched on and off. If, while current is flowing, the lead is rendered superconductive, the expulsion of flux from it causes a "kick," just as if the current had been switched off. Then, when the current is switched off there is no kick, for the coil is already non-inductive. One way of detecting transition to and from superconductivity is to note the sudden change in inductance of a coil, or in mutual inductance between coils placed at opposite sides of the tube containing the liquid helium superconductor.

## Practical Applications

There are lots of other entertaining things about superconductivity, but it is time to get down to the practical benefits, if any. Even with all the modern conveniences mentioned at the beginning, it may be felt that such benefits will have to be good if they are to justify the trouble of maintaining temperatures within a few degrees of absolute zero.

One attractive prospect is the near-elimination of circuit noise, for it is noise that sets the limit to useful amplification. However, it is not worth while going to much trouble to eliminate circuit noise so long as valve noise carries on regardless. Obviously valve heaters and liquid helium are not going to work well together. But what about transistors? They like to be kept cool! No doubt, but the semi-conductors of which they are composed increase greatly in resistance, while noise is not reduced; so the net result is unhelpful.

Another imaginable benefit is the raising of tuned-circuit Q to unheard-of figures. It has been reported that by abolishing resistance by superconductivity, Qs of the order of 10,000,000 have been observed. But who wants them? There are more convenient methods, such as crystals or positive feedback, for getting all the sharpness of resonance one can use.

What about making an electrical generator small enough to go into a flask of liquid helium but (because of its zero resistance) giving unlimited current output? That certainly would be economically worth while even if low-temperature techniques were more difficult than they now are. But an obvious snag is that a miniature generator would be

\* See for example two books:

"Superconductivity," by D. Shoenberg (Cambridge University Press, 1952).

"Superfluids" Vol. 1, by F. London (Chapman & Hall, 1950).

limited in the mechanical torque that could be applied without something giving way. A less obvious snag is that another low-temperature phenomenon steps in and strictly limits the amount of current that can be passed through the superconductors. The current inevitably creates a magnetic field, and if the field is strong enough it destroys the superconductivity, so that is that. This was strikingly demonstrated in an experiment with superconducting tin (which has a transition temperature of 3.73°K) which suddenly melted (505°K) when the current flowing through it exceeded the critical amount and its resistance was restored.

Although this magnetic effect squashes the pocket power-station idea, it opens up promising new possibilities. Fig. 6 shows how the transition temperature of lead, for example, is lowered by magnetic field. At 4.2°K (the boiling point of helium) a fairly strong field (about 550 gauss) is needed to destroy the superconductivity. But at 7° only about 40 gauss is needed, so a comparatively small current flowing through a coil around a lead wire can control a large current flowing through the wire. This is the basis of the cryotron.

In so far as "tron" suggests the proportional kind of control that is a feature of most other devices so designated, it is misleading, for the curve in Fig. 6 is a clear-cut and abrupt boundary between resistance and no-resistance. So the cryotron is most closely akin to the ordinary on-off relay. Another point of resemblance is that when "on" it can pass current either way, and (again unlike other "trons") it depends only on the strength and not the direction of the control current. But it has two practical advantages over the electro-magnetic relay: it is far smaller; and the controlling coil can have zero resistance, so requires no power.

These qualities are outstandingly valuable in digital computers, which consist mainly of vast quantities of on-off relays. We have all seen the impressive bulk, cost and power consumption of the major

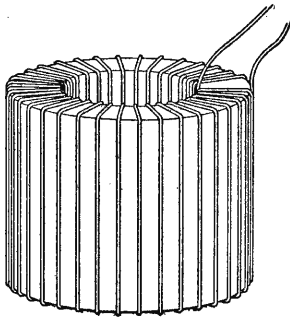
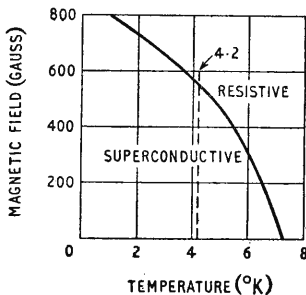

Fig. 5. Toroidal coil wound on a lead core; the coil suddenly becomes non-inductive when the lead becomes superconductive.

Fig. 6. Curve showing how the transition temperature of lead is lowered by a magnetic field. At 4.2° (the boiling point of helium) a considerable field is needed to restore the metal's resistance.



computers; if all that could be reduced to about one cubic foot and run on half a watt total (which is what we are told can be done by using cryotrons) the auxiliary low-temperature gear should more than pay its way.

The piece of wire whose superconductivity is switched on and off by the control coil is called the gate, and Fig. 6 shows that lead is not a very suitable metal for it. The simplest way of maintaining a given low temperature is by means of a liquid that boils at that temperature. The only liquid that boils within the superconductivity range is helium,

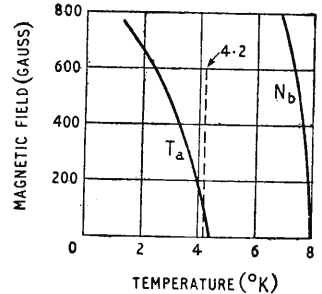

Fig. 7. Field/temperature superconductivity curves for tantalum and niobium—the two metals used for making cryotrons.

so in practice one can work at any temperature so long as it is 4.2°K! At that temperature an undesirably large control current is needed to cut off the superconductivity of lead. Tantalum, though expensive, is much more convenient, because its transition temperature starts at 4.4°K, as shown in Fig. 7.

### Something to Nothing

Cryotrons described by the inventor\* consist of one inch of 0.009-in (about 34 s.w.g.) bare tantalum wire surrounded by a single layer of 0.003-in (about 44½ s.w.g.) insulated niobium wire as control coil. The rather discriminating choice of niobium was presumably on the ground of its exceptionally high transition temperature (see Fig. 7) which ensures that it is superconducting all the time. As regards this, I suppose lead would be good enough, but trying to handle it in the form of 44½-gauge insulated wire might make it more expensive even than niobium!

At first thought it might seem that the resistance of an inch of wire at such a low temperature (being only a small fraction of its resistance at ordinary temperature) was already so low that switching it to zero by cutting off current through the control coil wouldn't make much difference—certainly not to be compared with the change made by parting the contacts of an ordinary relay. But a second thought should reveal that the two things are quite comparable, one being in fact the "dual" of the other. Passing control current through an ordinary relay reduces the current flowing via its contacts from something to nothing. Cutting off control current through a cryotron reduces the voltage across its gate element from something to nothing. No matter how low the resistance of a cryotron gate when control current is on, a superconducting gate in parallel with it is an infinite shunt which will prevent any current flowing through the first.

A very simple example of this is a circuit con-

\* "The Cryotron—a Superconductive Computer Component," by D. A. Buck. *Proc. I.R.E.*, April 1956, p. 482.

sisiting of two cryotrons in series with one another, gate and coil being transposed as in Fig. 8. If this arrangement were in series with a path passing more than what in bureaucratic circles would be called the minimum desuperconductancizing current, that current could pass through one or other of the parallel paths shown, but not both. For whichever control coil it was passing through would cut off current in the other path, thereby ensuring superconductivity throughout its own. This arrangement is, in fact, a bistable trigger circuit, equivalent to the Eccles & Jordan valve relay (but how much simpler!); one of the basic devices used in digital computers\*.

Just as a bistable valve system can be made to flip over by injecting a voltage pulse into it, so a cryotron could presumably be flipped by passing a current pulse through a reverse coil around the "closed" gate. For some reason not stated, but possibly to do with avoiding inductive coupling, the inventor prefers to use separate gates for triggering, as in Fig. 9. The action is a little more subtle than one might suppose. Assume that the upper path is passing current. Then everything is superconductive except  $G_3$ . Now pass a current pulse through the coil connected to  $O_{in}$ , sufficient to make  $G_0$  resistive. Both paths now have resistive gates, so  $I$  divides more or less equally between them and having been designed to be less than twice the strength needed to affect the gates it is no longer sufficient to make  $G_3$  resistive. The lower path therefore passes the whole of  $I$ , which renders  $G_2$  resistive, so keeping the upper path closed when the triggering pulse ends. The circuit will remain in the new state until a trigger pulse is applied to  $I_{in}$ .

Such a system is not much use in computers

\* Called in America a flip-flop, but in Britain that term is reserved for monostable or self-return systems.



Fig. 8. Two cryotrons in transposed series connection, forming a bistable trigger circuit. For clearness the control coils are shown beside the "gate" wires instead of wound around them as they actually are.

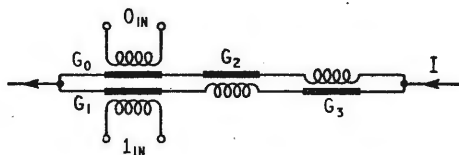

Fig. 9. Two more cryotrons added to Fig. 8 to enable the circuit to be triggered into either state by current pulses applied to  $O_{in}$  or  $I_{in}$ .

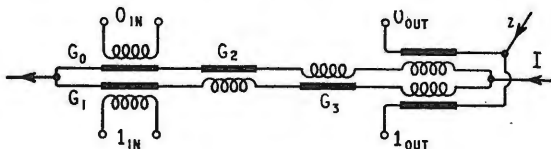
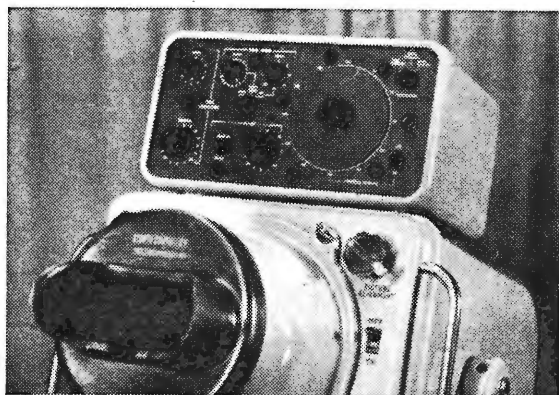

Fig. 10. Two more cryotrons added to Fig. 9 to enable the current pulses to  $O_{in}$  and  $I_{in}$  to switch a current  $i$  to either  $O_{out}$  or  $I_{out}$ .

unless it can switch an independent circuit; and Fig. 10 shows how another couple of cryotrons are connected to switch a current  $i$  to either  $O_{out}$  or  $I_{out}$ . And so a complete binary computer element is provided. Thanks to the compactness of the cryotrons, a ten-digit multiplication table can, it is said, among other facilities, be built into the one-cubic foot computer already mentioned. If you are well versed in computers you will know what that means, and if not it is too late to start explaining now.

## MARINE RADAR TRACK INDICATOR

A NEW control unit has been designed for use with Marconi Quo Vadis XII and Radiolocator IV systems which allows immediate selection of three types of radar presentation—north stabilized, ship's head up, or track indication. The first two of these provide the usual displays—anchor bearings, for example, can be quickly



Marconi Indicator fitted to Radiolocator IV equipment.

obtained from the first, and bow angles or relative bearings from the second.

The third of these displays shows true as distinct from relative motions. The course and speed of the observing vessel, and also independently the tidal drift are fed through the control unit to the centre of the p.p.i., so that it moves along the ship's course. True motions of the various objects are therefore seen on the screen; and in particular those which are stationary, such as buoys and light-ships, will remain so on the screen. On the shorter ranges the c.r.t. after-glow gives a "tail" behind moving objects.

When the observer ship's position reaches a suitable selected distance from the edge of the screen a warning note indicates that the display requires re-setting. A compass stabilized bearing indicator, which takes the form of a dotted line (to distinguish it from the full line heading marker) radiating from the observing ship's position, is available. If this is set to cut an object on the display the true bearing of this object can be read off on the scale provided.

"Transistor Communications Receiver."—In the description of this instrument on page 281 of the June issue the prices given were incorrect. The "Homer" receiver now costs £39 and the "Heron" d.f. aerial £14 12s.



**New Microwave Ferrites** with the desirable properties of controllable saturation magnetization, low dielectric loss, and high degree of reproducibility have been developed by L. G. Van Uitert, of Bell Telephone Laboratories. As already described in *Wireless World*, ferrite components inserted into waveguides can perform quite complex circuit functions by utilizing ferromagnetic resonance and other phenomena (see December, 1956, issue, p. 595). The new materials are essentially magnesium, manganese, aluminium ferrites or nickel manganese ferrite with a small amount of copper replacing some of the magnesium or nickel. The addition of the proper quantities of copper and manganese to the basic ferrite is advantageous from several points of view. By increasing the reactivity of the mixture, copper decreases the necessary firing temperature by at least 100°C. Under comparable conditions this results in lower porosity and improved uniformity in the fired material. The manganese addition decreases electrical conductivity and hence the dielectric losses in these low porosity materials. Microwave ferrites with low saturation magnetizations are obtained by the modification of magnesium ferrite. The saturation magnetization of this ferrite can be decreased in a controlled way by substituting aluminium for a part of the iron. While materials compounded in this fashion are basically satisfactory, their refractory nature makes it difficult to reproduce the magnetic properties required for many microwave applications. The added copper minimizes this difficulty, and also increases slightly the Curie temperature for comparable saturation magnetization.

**Twin-Triode Transistor** consisting of two n-p-n units, with a common piece of germanium forming the emitter of one and the collector of the other, has been developed by General Electric in the U.S.A. The structure is shown at the top left of

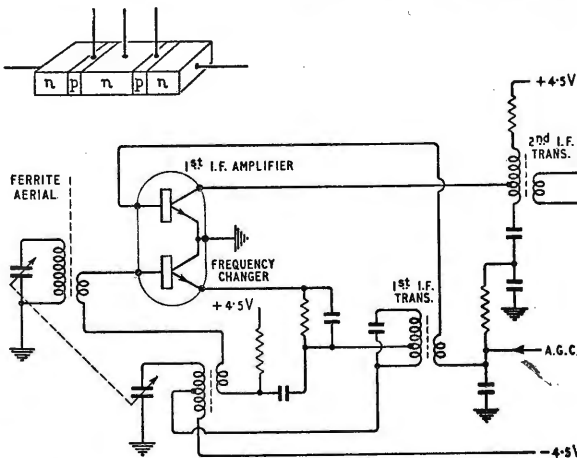

# Technical Notebook

the illustration, while the graphical symbol appears in the circuit below. The idea is, of course, to reduce the cost of transistor sound broadcast receivers, and a set using two of the tetra-junction units in place of four ordinary transistors was described in the April, 1957, issue of *Electronics*. The "front end" of the circuit, as shown, uses a tetra-junction transistor to provide an autodyne frequency changer and an i.f. amplifier. Since the two structures are in series, twice the normal supply voltage is required and the receiver uses two 4.5-V batteries in series with their centre point earthed. As the common element of the tetra-junction transistor is earthed the two sections function independently, the top half as a common-emitter earthed-emitter stage and the lower half as a common-emitter earthed-collector stage. The other tetra-junction transistor in the set is used as a combined second i.f. stage and audio driver stage.

**Metal-screen Circuit Printing** of high accuracy and consistency was recently demonstrated by Gordon & Gotch on a new German screen printing machine specially designed for this type of work. Screen printing with a stencil is a very simple and convenient method of laying a heavy deposit of acid-resistant ink on the copper to be etched, but when the traditional silk screen is used the accuracy of registration is not very high. The new machine, however, uses a metal gauze screen with a

metal stencil bonded to it, made by The Royal Mint Refinery. This is stretched over a frame and tightened by means of an inflatable tube round the edges—a system by which the applied tension is equalized all round to give very even stretching. Apart from its dimensional stability, the metal screen stretched in this way has the advantage of greater elasticity



than the normal silk screen when the ink is being pressed through it with the squeegee. This means that the screen springs away from the work immediately after the squeegee has passed on, and there is no time for the ink to drift and slur away from the required pattern. Stainless steel or bronze (which is cheaper) can be used for the screens. While printing is taking place the work is held completely flat on the bed of the machine by a powerful air suction system. Gordon & Gotch are the sole agents in the U.K. and Ireland for the machine, which is made by Siebdruckgeräte von Holzschuher.

**Industrial Linear Accelerator** has been built by Mullard for giving high-energy X-rays for radiographic examination of large metal specimens. Despite its high energy of 5 MeV, and the large X-ray output of over 500 roentgens per minute at 1 metre, the electron beam has a diameter of only 2mm when it strikes the target. Moreover, the polar diagram of the



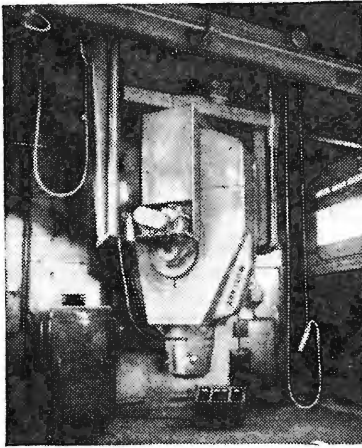

output tends to be flatter than is normally associated with such a high energy beam because of a magnetic focusing device in the X-ray head. Another feature of the machine is its high degree of mobility—a desirable thing when dealing with bulky specimens. The X-ray head itself rotates, while the whole machine can be tilted from vertical to horizontal, turned laterally through 180°, raised or lowered 8ft, and is mounted on an overhead rail to permit transverse and longitudinal movements.

**Irradiated-Polythene Encapsulation** of small components is possible by a simple method using extruded sleeving of this material. The inside diameter of the sleeving, initially  $\frac{1}{8}$  inch, can, after irradiation, be enlarged while cold to  $\frac{1}{2}$  inch or more to fit over the components. Upon momentary heating to 135-150°C, it attempts to return to its original  $\frac{1}{8}$ -in inside diameter and so effectively encapsulates the component. Irradiated polythene is, of course, well known for its ability to withstand higher temperatures than ordinary untreated polythene. It is also free from stress cracking in the presence of detergents and has increased resistance to the action of hydrocarbons. Tensile strength and abrasion resistance are both improved. The irradiated polythene insulation of a new equipment wire recently introduced by Mersey Cable Works (who also supply the encapsulation sleeving) has a maximum continuous operating temperature of 100°C and a short-term operating temperature of about 150°C. Whereas normal polythene melts at about 115°C, the irradiated version is merely converted to a rubber-like substance at this temperature and is claimed to have some useful strength even up to 450°C.

**Data Magnetic Recording Heads** of high precision and multiple construction are now being made com-

mercially for use in magnetic tape data storage systems. The types shown in the illustration (from the Data Recording Instrument Company) are for 10, 8 and 4 tracks respectively. They give a track width of 0.03in, with a separation between centres of 0.06in. The pole face has 0.2in in contact with the

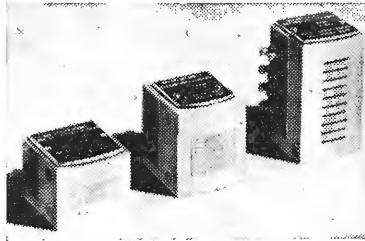

magnetic tape, while the gap length is 0.0004in—a figure determined from the frequency response curve. The bias current required is 8mA r.m.s. and the recording current 1mA r.m.s. (10mA for tape saturation). Output on replay is 0.25mV r.m.s. at 10kc/s with high tape speeds in the region of 100 inches per second.

**“Television” Electric-Field Mapper** for high-speed plotting of analogue fields in an electrolytic tank, built by R. B. Burt and J. Willis, enables changes to be made in the tank and the results to be seen immediately as a moving picture on a c.r.t. raster. It avoids the extreme slowness and tedium of the traditional method of plotting equipotential lines (in which a probe has to be moved about in the tank), and a complete field is mapped in 1/25th

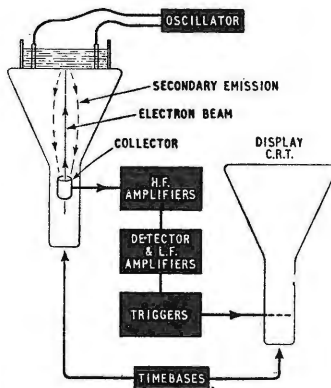

of a second. The tank is built on the screen of a c.r. tube as shown, and a 100-V carrier signal from a 75-kc/s oscillator is applied across it. This signal modulates the secondary emission current returning from the screen to the final anode, which acts as a collector. After amplification the carrier signal is detected and its envelope is a low-frequency waveform produced by the

scanning of the pattern of equipotential lines in the tank. This i.f. waveform is then divided up into seven equipotential values by trigger circuits, which apply corresponding darkening pulses to the grid of the display tube. The timebases generate a line scan frequency of 3,000c/s and a frame frequency of 25c/s, giving a raster of just over 100 lines. Full details and examples of field maps appeared in the May, 1957, issue of the *Journal of Scientific Instruments*.

**Electronic Photo Printer** is a device working on a feedback principle for printing photographic negatives in such a way that the maximum possible detail is obtained regardless of the amount of exposure. Normally, of course, it is quite common for a negative to have too great a range of densities for the printing paper to reproduce all the detail. This is overcome in the electronic machine by using a scanning c.r. tube with a television-type raster as the printing light source, and a photocell for picking up the transmitted light to give a signal for controlling the brightness of the c.r. tube. Thus when the less dense areas of the negative are scanned the feedback signal causes the printing light to be reduced and when the more dense areas are scanned the light is increased. The illustration shows the production model of the Cinema-Television equipment which was originally described in our June, 1956, issue (p. 272). E.M.I. Electronics have recently secured the rights to manufacture in this country an electronic photo printer made by the American firm LogEtronic.

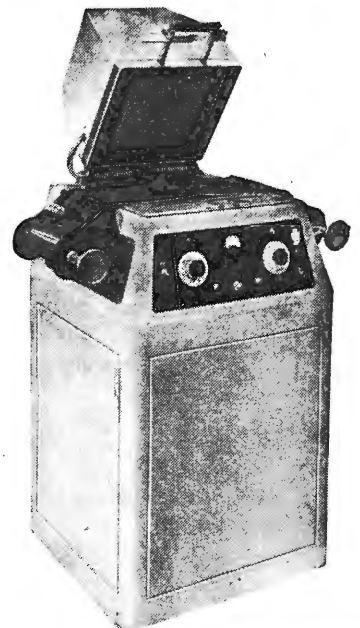

# Transistor Circuit Symbols

By E. H. COOKE-YARBOROUGH,\* M.A., M.I.E.E.

FOR several years the symbols used to represent transistors in circuit diagrams have been subject to a good deal of discussion. "Cathode Ray" has therefore performed a valuable service† in pointing out the need to use transistor circuit symbols which distinguish between point-contact and junction transistors, and in tabulating the various symbols which have been used to make this distinction. There is a further, and perhaps even more compelling, reason for ensuring that this distinction is clearly made. Probably the most important difference between the two kinds of transistor is a purely elec-

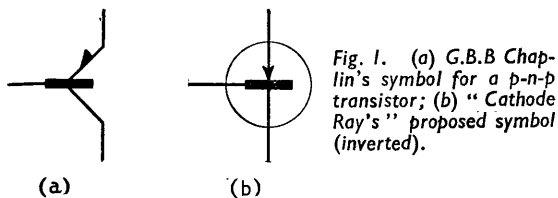

trical one: while the emitter current gain of a junction transistor is normally less than one, that of a point-contact transistor normally exceeds one. Thus the phase relationship between the emitter and base currents of a junction transistor is opposite to that of a point-contact transistor. The action of many transistor circuits cannot therefore be readily understood unless the diagram shows clearly which type of transistor is used.

"Cathode Ray" rejects the junction transistor symbol proposed by Chaplin,‡ which has been in general use at Harwell for some years, but he supports a symbol (illustrated in Fig. 3 of his article) which differs from Chaplin's symbol for a p-n-p junction transistor (Fig. 1(a)) only in three respects. The first is that of polarity, and if for the moment we avoid this question by turning "Cathode Ray's" symbol the same way up as Chaplin's, we have Fig. 1(b).

The only significant differences are now the angle at which the emitter and collector leads join the base and the use of a circle to enclose the symbol. These two differences are relatively minor; the reasons for joining the emitter and collector leads to the base at an angle of 45° are, first, to prevent possible visual confusion, which might result if emitter and collector appear to lie on a continuous straight line, and second, to provide a link with the point-contact symbol, where the emitter and collector also join the base at an angle of 45°. The circle can easily be left to individual choice. When the circuit is simple and the transistor symbol is boldly drawn the circle appears to be superfluous, but if the circuit is complex, containing many transistors, and the symbols are therefore small, the circle is undoubtedly helpful.

If one accepts these small concessions to indivi-

dualism, none of which is likely to lead to ambiguity or misunderstanding, then Chaplin's p-n-p symbol and that advocated by "Cathode Ray" amount to practically the same thing (except for polarity). There is already considerable support for the use of a junction transistor symbol of this sort. Such a symbol is in use by at least one University department, by at least one large industrial organization, and by at least three Government research establishments. Moreover, all but one of the papers presented last year at the I.E.E. Computer Convention used junction transistor symbols of this sort.

Turning now to the question of distinguishing between a transistor with an n-type base and one with a p-type base, reversal of the direction of the emitter arrow does not by itself appear to provide an obvious enough distinction. This view is supported by the circuit diagram on page 152 of the issue in which "Cathode Ray's" article appears. Here the single n-p-n transistor is quite hard to recognise, despite the fact that the caption draws attention to it. Some more obvious distinction therefore seems desirable, and that used by Chaplin, which is shown in the symbol of Fig. 2, appears to be logical. Even if, to save trouble, the n-type base is represented by a thin line as in "Cathode Ray's" Fig. 3 (a), it should not be too difficult to make the base an open rectangle when a p-type base is being represented.

This brings us to the question of the polarity convention used in circuit diagrams. As "Cathode Ray" points out, this has, in valve circuits, nearly always been "positive above the earth line, negative below." "Cathode Ray" seems uncertain whether the same convention should be used in transistor

Fig. 2. Chaplin's symbol for an n-p-n transistor.

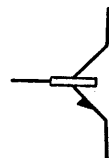

circuits, and puts forward the often-heard argument that a "negative up" convention makes it easier to draw attention to parallels between valve circuits and transistor circuits.

True, the teaching of transistor circuits is simplified if the similarities between these and valve circuits are brought out, but is it right to choose a polarity convention which deliberately sets out to obscure a most important difference between valves and p-n-p transistors? This will only lead to greater difficulties later on. Admittedly in truly linear circuits we do not have to worry much about polarities, but when we come to consider class-B amplifiers or the effects of overloading in an amplifier, we begin wondering whether a positive base voltage will increase or decrease collector current, and here the trouble starts.

In pulse circuits we are in worse trouble still, for

\* Atomic Energy Research Establishment, Harwell.

† "Cathode Ray," *Wireless World*, pp. 194-198, April 1957.

‡ G. B. B. Chaplin, *Proc. I.E.E. Part B*, p. 788, Nov. 1955.

such diagrams often include sketches of waveforms. If a circuit diagram is made "negative up," what convention is to be used for the waveforms? If these are made "negative up" also, we must reverse the connections of our oscilloscopes and many of us must reverse some connections in our minds! One even encounters transistor pulse circuit diagrams, using a "negative up" convention, which include waveform diagrams whose polarity is not indicated, but which turns out on inspection to be "positive up." Presumably it is possible to school oneself to correlate "positive up" waveforms with a "negative up" circuit diagram, but are such mental gymnastics really necessary? Can it be said that they help the student? When p-n-p and n-p-n transistors are mixed, the last shred of justification for a "negative up" convention disappears.

It does seem, therefore, that there is a strong case for keeping to the "negative down" polarity convention already established with valve circuits and accepting the fact that the newcomer to transistor circuits may at first be a little shocked by seeing the earth line at the top of the diagram and the rest of the circuit "underground." As "Cathode

Ray" suggests, this blow can be softened by referring initially to n-p-n transistors.

Last, but not least, we must consider the current recommendations of the British Standards Institution. So far as the polarity convention is concerned, there already exists a B.S.I. recommendation for "positive up, negative down." With regard to symbols, the writer is in no position to speak for the B.S.I. but it is not difficult to see why the "point-contact" symbol is at present recommended for both types of transistor. To quote from a letter written by the late L. H. Bainbridge-Bell, "B.S.I. exists to standardize usage and not to invent symbols." Now "usage" is determined ultimately not by committees but by everybody concerned with transistor circuits. Already many people are using junction transistor symbols like those of Fig. 1. We need not worry too much about the odd details, but if enough people subscribe to the view that a symbol of this sort is the right one for junction transistors and that circuit diagrams should be drawn "negative down," then this can quickly become "usage," to the ultimate advantage of all who work with transistor circuits.

## BOOKS RECEIVED

**Guide to I.G.Y.**, by members of the British Committee. Covers research projects of the International Geophysical Year, including rockets and the satellite programme, and suggestions for simple observational work (non-radio). Pp. 48; Figs 22. Price 2s 6d. Methuen and Co., Ltd., 36, Essex Street, London, W.C.2.

**Semi-conductors: Their Theory and Practice**, by G. Goudet and C. Mealeau. Covers theoretical quantum mechanical aspects and electric current in solids; properties, preparation and measurement of semi-conductors (including thermistors); and characteristics and applications of semi-conductor diodes, triodes and tetrodes of various types. Pp. 316; Figs. 146. Price 105s. Macdonald and Evans, Ltd., 8, John Street, London, W.C.1.

**Year Book of the Physical Society, 1956.** Includes texts of the principal special lectures delivered before the Society, e.g., 32nd Duddell Medal Address, "Some Recollections of the Early History of the Travelling Wave Tube," by R. Kompfner. Pp. 76. Price 10s 6d by post. The Physical Society, 1, Lowther Gardens, Prince Consort Road, London, S.W.7.

**A V.H.F./U.H.F. Field Strength Recording Receiver Using Post-detector Selectivity**, by R. V. Harvey, B.Sc., G. F. Newell, A.M.I.E.E., and J. G. Spencer. B.B.C. Engineering Monograph No. 6 describes measuring equipment, and discusses gain in signal-to-noise ratio obtained by using this type of circuit. Pp. 26; Figs. 19.

**Engineering Training in the B.B.C.**, by K. R. Sturley, Ph.D., M.I.E.E. B.B.C. Engineering Monograph No. 11 describes organization, types of training and facilities available. Pp. 24; Figs. 9.

**An Improved "Roving Eye,"** by T. Worswick, M.Sc., A.M.I.E.E., and G. W. H. Larkby. B.B.C. Engineering Monograph No. 12 gives full details of cameras, radio equipment and vehicle in this second design; and also includes a new method of providing "in-shot" warning for television operators. Pp. 20; Figs. 11.

The above B.B.C. Monographs are each priced 5s, and can be obtained from B.B.C. Publications, 35, Marylebone High Street, London, W.1.

**Introduction to Printed Circuits**, by R. L. Swiggett. Describes construction, components, assembly and servicing of various basic types of printed circuit. Pp. 98;

Figs. 83. Price 21s. Chapman and Hall, Ltd., 37, Essex Street, London, W.C.2.

**Über die Anwendung von Ferriten zur Amplitudenmodulation von Mikrowellen**, by M. Santemas, D.Sc.Tech. Monograph No. 24, from the Zurich Institute for High Frequency Techniques, investigates the application of ferrites to modulation at X-band with special reference to modulation quality and shielding by the waveguide. Pp. 43; Figs. 26. Price 5.20 Fr. (Swiss). Leeman, 20 Arbenstrasse, Zurich 8.

**Hi Fi Yearbook**, edited by M. Henslow. 1957 edition of this book has comprehensive set of articles together with brief specifications and many illustrations of commercial equipment in a directory of manufacturers. Pp. 208. Price 10s. 6d. Miles Henslow Publications, Ltd., 99, Mortimer Street, London, W.1.

**Transistors: Circuits and Servicing**, by B. R. A. Bettridge, A.M.Brit.I.R.E. Explains the working and circuit uses of transistors with emphasis on servicing problems. Pp. 23; Figs. 11. Price 2s 6d. Trader Publishing Co., Ltd., Dorset House, Stamford Street, London, S.E.1.

**The Instrument Directory and Buyer's Guide.** 1957 edition covers all types (including electronic) of industrial instruments. Pp. 244. Price 10s. United Trade Press, Ltd., 9, Gough Square, London, E.C.4.

**Metal Industry Handbook and Directory.** 1957 edition covers metal and alloy properties, general data and tables and various directories. Pp. 566. Price 15s. Iliffe and Sons, Ltd., Dorset House, Stamford Street, London, S.E.1.

**The Radio Amateur's Handbook**, 1957 edition; by the technical staff of the A.R.R.L. Comprehensive manual for the radio amateur, explaining basic radio principles, current operating procedure, layout of stations and design and construction of aerials and equipment for all amateur bands. Pp. 608, including 32 pp. of tabulated valve and transistor data; over 1,350 illustrations. Obtainable from The Modern Book Co., 19-23, Praed Street, London, W.2, or from the R.S.G.B., New Ruskin House, Little Russell Street, London, W.C.1; price 32s 6d (34s by post).

# Instruments Electronics and Automation

SOME INTERESTING ITEMS FROM  
THE OLYMPIA EXHIBITION



Metropolitan-Vickers "950" transistor digital computer.

**A**T an exhibition primarily directed at the *user* of electronic instruments and devices one would not necessarily expect to find a large number of new and advanced techniques. There were, in fact, plenty of well-established products at the recent I.E.A. Show which had previously appeared in other, more restricted exhibitions. It must be remembered that things the electronics technician has known about for years may still be quite novel to the potential user and the general public.

With this in mind, *Wireless World* has been fairly selective in its review of the Show, and the following itemized report is restricted to things of outstanding technical interest which have not been previously described in the journal. Laboratory test instruments shown at this and at the Physical Society's and R.E.C.M.F.

exhibitions are dealt with elsewhere in the issue.

**Transistor Digital Computer**, the first to appear in Britain in commercial form, was shown by Metropolitan-Vickers. It is a serial binary machine based on a magnetic drum storage system which provides a main store of 4,096 "words" (of 32 binary digits each) and various registers working on the regenerative principle (the output from a "read" head being fed back to the "record" head on the same track). The drum also generates the basic clock pulse frequency of 57kc/s. The transistorized arithmetic circuits are mounted on plug-in printed-circuit boards. Point transistors, using the well-known regenerative switch-over action, provide the two-state elements, while junction transistors are used for inverter and power ampli-

fier circuits. The logical gates for performing the binary arithmetic are constructed from point-contact diodes. These basic arithmetic elements are organized into an adder-subtractor unit (using a regenerative track on the drum as a two-word accumulating register) and a multiplier which itself includes the multiplicand register. The control system for ordering the sequence of arithmetic operations is actuated by coded instructions of the two-address type. These, and the actual numbers for computation, are fed into the machine by five-hole punched paper tape. Output data also appears on punched tape or can be printed automatically on a page.

**Basic-Instruction Computer**, a digital machine shown by Standard Telephones, has been designed in collaboration with the Netherlands P.T.T. and is based on logical principles devised by Prof. van der Pol. The instruction code is built up from "operational" digits, each of which actuates a basic logical operation in the machine. This allows more flexible programming than in computers where the code is restricted to a small number of predetermined operations and also simplifies the arithmetic and control circuitry. Again, the computer is a serial binary type, working at a clock-pulse frequency of 128kc/s and based on a magnetic drum store with a capacity of 8,192 "words" (of 33 binary digits each). Symmetrical junction transistors are used for switching between the tracks of the drum. Punched tape provides the input and output media (with the alternative of direct page printing for the out-

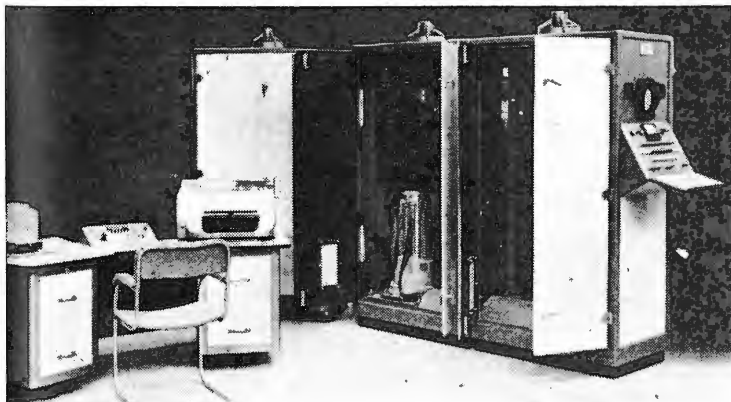

S.T.C. "Zebra" digital computer with doors open showing the magnetic drum store. The control desk is on the left.

put). The arithmetic and control circuits, using crystal diodes and thermionic valves, are constructed as plug-in functional units with insertion handles over the valves, and the interconnections between them are made by large printed-circuit panels at the rear. An unusual feature of the construction is the use of wrapped-joint connections on the plug-in units instead of soldered connections—a technique borrowed from the manufacture of telephone exchanges.

**Decimal Digital Computer** shown by Southern Instruments is a simple and inexpensive machine which can be considered as a fast electronic version of a desk calculator. Primarily intended for engineering calculations, it has storage registers consisting of rows of Dekatron tubes, each register having a capacity of 12 decimal digits. Arithmetic operations are performed in accumulating registers of this type, and numbers are transferred in parallel form—that is, all the digits move simultaneously on multiple bus-bars. The switching which performs the actual transfer, and indeed the whole control sequence of the computer, is done by electromechanical relays, and this, of course, limits the speed of operation. The transfer of a number, which can if necessary include addition or subtraction with another number, takes 180 milliseconds. Multiplication and division take several seconds. Later, however, it is expected that higher speeds will be obtained when electronic switching is used. For feeding in the numbers and coded instructions, three facilities are provided. Manual operation of a keyboard can be used for single calculations where no programming is involved; a plug-board

can be brought into play for calculations requiring up to 100 steps—the rows of plugs setting up patterns of connections which are scanned in sequence by a programme unit; while punched tape is employed whenever a programme has to be repeated many times with different input data.

**Continuous Drift Correction** is a new feature of the d.c. amplifiers in the general-purpose electronic analogue computer made by Short Brothers and Harland. A good deal of analogue computation is done with repetitive operation (the results being displayed continuously on a c.r.t.) and here the drift correction is normally applied during the intervals between solutions (i.e., between strokes of the c.r.t. timebase). With continuous or "single shot" computation, however, the d.c. amplifier may be in operation for periods of several minutes, and this technique cannot be used. The Short and Harland method, then, uses an auxiliary a.c. amplifier which continuously samples the drift voltage and applies appropriate correcting signals. This amplifier is connected in cascade with the computing amplifier when integration is being performed, but is automatically switched into parallel connection for adding—the idea being to avoid phase shift which could introduce errors into the adding operation.

**Magnetic-Tape Data Storage**, for digital computing applications, has the advantage of large capacity over other methods, and a new machine shown by Pye will accommodate 1½ million binary digits per channel in a 2,400-ft spool of tape at a density of 100 pulses to the inch. The tape will take eight channels on ½-inch width (or four channels on ¼-inch

width) and runs at the high speed of 100 inches per second. This speed is necessary to reduce the access time to data inherent in a sequential method of storage—as is also the fast start/stop/reverse mechanism which operates in less than 10 milliseconds. An electro-pneumatic system is used for this mechanism, the tape being brought into sudden contact with the driving capstans by air suction through holes in the capstans.

**Variable Delay Line**, for radar signal simulation and other purposes, was demonstrated by Mullard. It has a delay continuously variable from 25 to 330 microseconds and a bandwidth of 8Mc/s on a centre frequency of 15Mc/s. Mercury is used as the delay medium and the signals are converted into ultrasonic energy by a quartz crystal transducer for transmission through it. The sending and receiving crystals are mounted side by side, and transmission from one to the other is effected by a corner reflector mounted on a sliding piston driven by a lead screw, the position of which determines the amount of delay. The pitch of the lead screw is such that one revolution corresponds to a delay change of 10 microseconds. The complete unit contains, in addition to the delay line proper, input and output amplifiers, power supplies, and a Velodyne motor and amplifier for driving the lead screw (although manual operation is possible as well). The Velodyne unit can be controlled by either an external or an internal voltage and it gives a maximum rate of change of delay of 3 microseconds per second.

**Telemetering Heartbeats by radio**

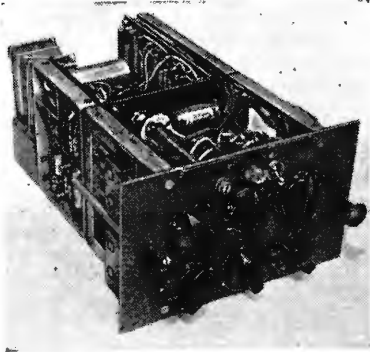

Drift-corrected d.c. amplifier unit from the Short and Harland analogue computer.



Southern Instruments "Deciplex" decimal digital calculator.



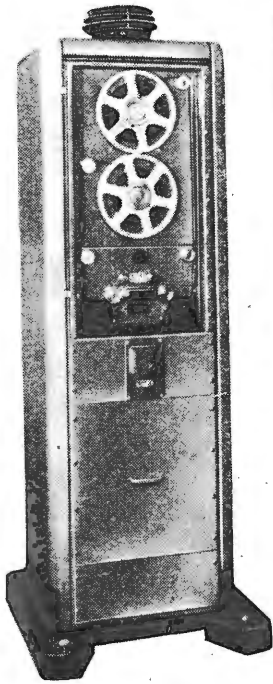

Above: Pye magnetic tape data storage equipment.

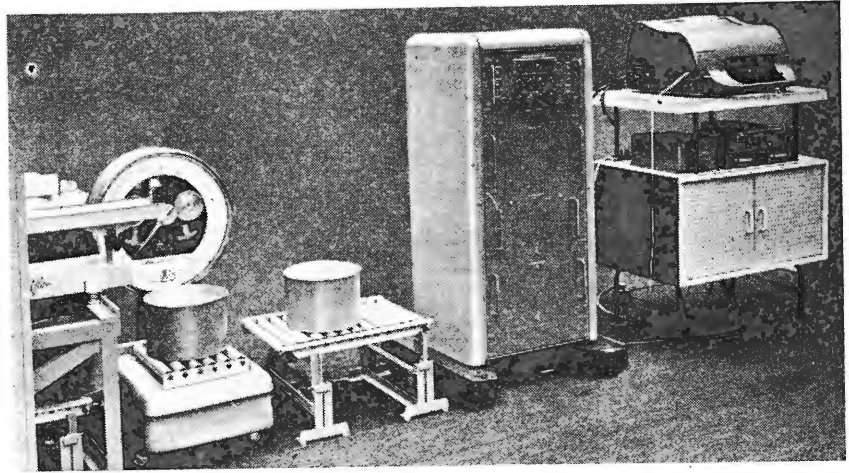

Electronic digital weighing system (E.M.I. Electronics) with automatic "print out" on the right.

Right: Variable ultrasonic delay line (Mullard).

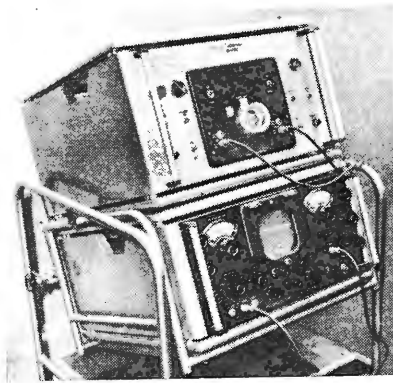

from a person engaged in vigorous activity was demonstrated by the Ministry of Supply as a means of testing clothing for soldiers—the heart rate being used to establish the exhaustion limit of the subject. Electrical activity from the surface of the body, containing both heart-muscle potentials and voltages from other muscles, is taken from three areas and amplified. The amplified signals are then fed into a coincidence gate circuit so that only the electrical activity common to all channels—that of the heart—is accepted for pulsing the radio transmitter. Discrimination of the required potentials is, in fact, very difficult, and to assist the process a regenerative circuit is used in which the coincidence gate output is fed back to the input of the system. When the gate output is of large enough amplitude the gain round the loop is sufficient to start an a.f.

oscillation, and the final result is to produce a short "pip" of tone whenever a heartbeat potential is detected. The radio transmitter is a tiny two-valve unit weighing only 3½oz and operating on 40Mc/s c.w. Its oscillator is grid-modulated by the "pips" of a.f. tone.

**Electronic Weighing system** shown by E.M.I. Electronics indicates a measured weight in digital pulse form which can be used for direct printing on an automatic typewriter or for triggering other processes in an automation system (e.g., when the weight reaches a certain value). A conventional weighing machine has an optical "digitizer" (a commutator disc with black and white graduations) attached to its pointer shaft. The rotation of the digitizer causes pulses of light transmitted through the graduations to fall on a photocell, so that the number of electrical pulses generated corresponds to the

angular displacement of the disc and hence to the measured weight. These pulses are counted by a Dekatron counter which has bi-directional properties; the digitizer rotating in the "increasing weight" direction causes the glow discharges to move clockwise and in the "decreasing weight" direction causes them to move anticlockwise. The damped mechanical oscillation when the weighing machine is settling down produces a corresponding fluctuation in the count, and it is the cessation of this oscillation which allows the Dekatron count to be "read out" as true weight to the automatic typewriter. In the Elliott electrical weighing system, which has been applied in crane load weighers, weighbridges, etc., the distortion of a ring is measured by means of resistance strain gauges. Direct reading on a dial is given by a self-balancing bridge.

**Machine Tool Control** involving direct measurement of the position of the work table is the ideal method but can become quite elaborate and expensive. In the Ekco Type E117 system the equipment required is simplified by controlling the rotation of the lead screws on existing machines. Electric motors driving the lead screws are controlled by counters which record complete revolutions and by 360° master potentiometers in conjunction with Wheatstone bridges for intermediate settings. These are arranged to give decade control in inches and have a potential accuracy of 0.0001in, assuming perfect lead screws. As an alternative to the existing dial-setting control unit, a punched card

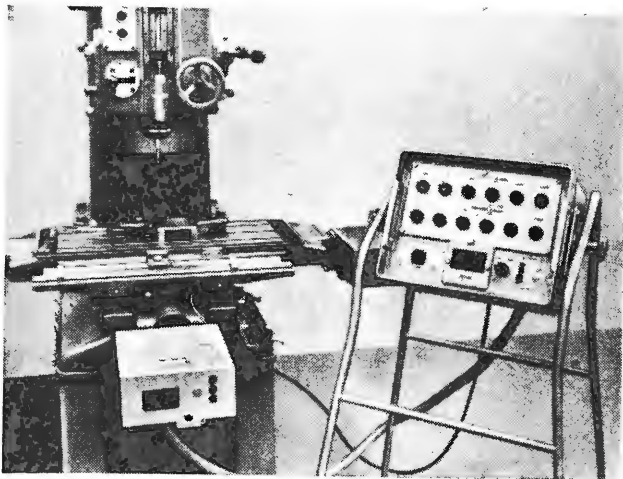

Left: Ekco machine tool control system (Type E117).

information storage system with up to twelve locations is under development. Errors from worn or otherwise imperfect lead screws can be offset by inserting corrective data in the control information, or simply by a calibration run each time the machine is set up. Such errors do not affect the repeat accuracy of the machine.

In a system of machine tool control under development by Lawrence, Scott and Electromotors, Ltd., displacement is converted to angular motion by an arm of fixed length attached to the spindle of a mag-slip resolver. The voltage output from the resolver is proportional to the sine of the angular movement and so to the distance of the probe arm from a zero reference plane such as the face of a gauge plate. Readings accurate

to 0.0002 in in 5 inches are possible. The range can be extended and the system controlled by reference to voltages provided by toroidal voltage dividers.

**Moisture in Building Structures** is a difficult quantity to measure by conventional methods, but it has been established that a linear relationship exists between moisture content and the absorption of centrimetric waves when expressed as attenuation in

decibels. In order to exploit this method of non-destructive testing W. H. Sanders (Electronics), Ltd., have developed a system in which microwave transmitting and receiving horns are applied to opposite sides of a wall or to any bulk specimens of which the moisture content is required.

**Ultrasonic Inspection** of raw materials and finished structures is now widely accepted as a necessity and has long passed the laboratory and development stage. In the Kelvin Hughes system of "Autosonics" continuous routine inspection can be carried out without the need for a skilled operator, and can be adapted to a variety of industrial requirements. One essential feature of the system is the use of automatic gain control from one of the fixed return pulses to compensate for variations in

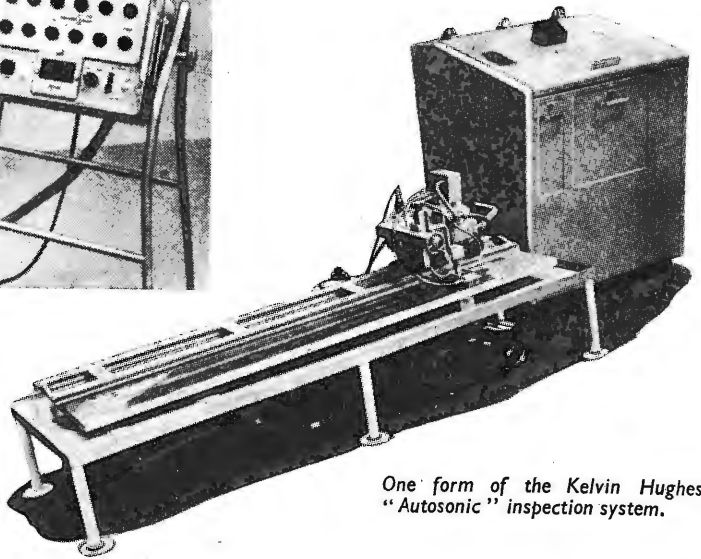

One form of the Kelvin Hughes "Autosonic" inspection system.

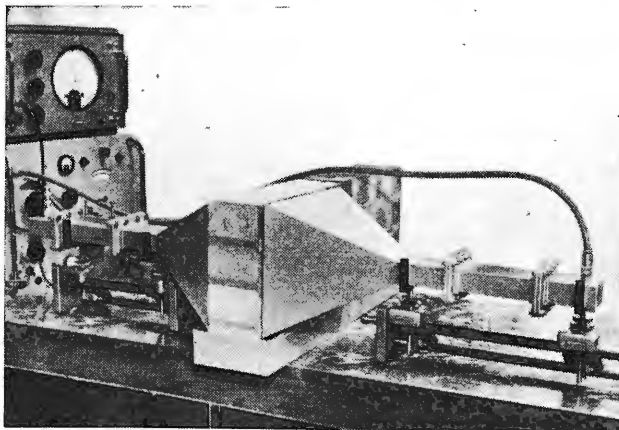

Microwave attenuation as a means of measuring moisture content (W. H. Sanders (Electronics), Ltd.).

Right: Acoustic burglar alarm (Cinema-Television).

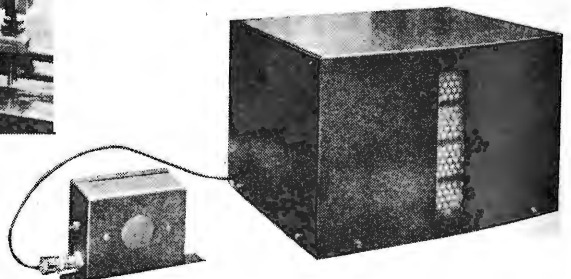



the acoustic coupling between the probes and the specimen under test. The other is the use of electronic "gates" to select defects above a given amplitude, and to select, when required, different strata of the material for detailed inspection. The output can be applied either to a

recorder or to an automatic alarm. An **Intruder Alarm** developed by Cinema-Television, Ltd., works on acoustic principles and has many advantages over trip wires or infrared beams. An electrostatic loudspeaker establishes a standing wave pattern in the air of the room and a

microphone is set some distance away near one of the vibrational nodes. The entry of a person anywhere in the room disturbs the standing wave pattern and so increases the output from the microphone, which can be arranged to set off an alarm.

## NOISE

### Two Unusual Aspects seen at this Year's N.P.L. Open Day

NORMALLY thermal noise in resistors is a limiting factor of performance to be circumvented as far as possible. It was therefore surprising to find deliberate use being made of such noise in temperature measurement at one of the exhibits shown at the recent open day of the National Physical Laboratory. Two very thin platinum-rhodium wires of about 2,000 ohms resistance are used as noise sources, one being at a standard, and the other at the unknown temperature. The noise voltages for each of these (proportional to their absolute temperature) are connected in rapid succession by a vibrating switch to a high-gain amplifier. The larger signal passes through a precision attenuator and the final voltage difference between the two signals is stored in condensers and displayed on a cathode-ray tube. The attenuator is adjusted until the fluctuating difference is small. This difference is then read a large number of times, and from the relative frequency of the various individual readings the mean can be determined. It is hoped by this method to obtain an accuracy somewhat greater than the standard gas thermometer at temperatures around and above 1,000° C.

"Free Grid's" miniature magnetron transmitter mentioned in last month's issue (p. 302) does not seem to be so absurdly beyond the bounds of possibility when we consider another N.P.L. exhibit, the "dimple arc" microwave source\* which consumes only one or two watts at six volts. This source is based on a very short (probably less than 10μ long) mercury discharge arc, which is obtained by striking a normal vacuum arc between a liquid mercury cathode and a vertical thin tungsten wire anode. If this wire is thin enough to become red-hot when the arc is started, and is carefully lowered towards the cathode pool, its tip makes a dimple in the liquid surface. The arc immediately transfers to within this dimple which is kept in being by vapour evolution from the cathode spot. The very

short arc is obtained by careful adjustment of the penetration of the wire below the free mercury surface, and of its temperature (by varying the arc current). This arc is a

copious emitter of microwave noise extending at least from S-band (around 3,000 Mc/s) to beyond Q-band (around 36,000 Mc/s). The noise probably arises from inherent instability in the cathode electron emission. More puzzling are the larger peaks of noise also observed at various frequencies, which may give of the order of ½ mW power.

\* See letter by K. D. Froome in *Nature* for February 2nd, 1957.

## Pickup Alignment Protractor

TO keep the distortion introduced by pickup tracking error to an acceptably low figure only small amounts of this error up to a few degrees can be tolerated. The B-J protractor enables the tracking error to be measured at any radius on the record. It is based on a 1925 design by Wilson.

The instructions are simple to follow but care must be taken over

provides a check on a possible cause of distortion. The method of measurement suggests a less obvious way in which such error can creep in. It assumes that the needle axis is at right angles to that of the outer shell. Where a cartridge is fixed to this shell through slots to allow play for positioning this may not be exactly so, and a corresponding error may be introduced. A similar error may

Burne-Jones Alignment Protractor

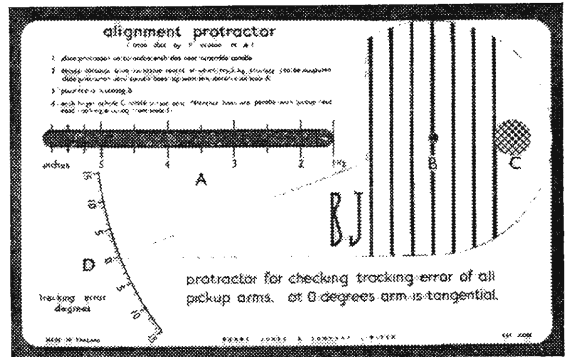

the measurement. For instance, some play of the stylus in the seating provided is possible. This can lead to some uncertainty in the measured tracking error up to between about ½ and 1½ degrees at the outer and inner record grooves respectively. By carefully centralizing the stylus in the seating, or taking the mean of the two extremes, it is not difficult to eliminate this error.

This tracking error measurement

also arise due to inaccurately shaped cartridges or shells. In at least one pickup the cartridge is actually deliberately misaligned with the outer shell to provide the necessary offset, and so an equal allowance would have to be made in measuring the tracking error of this pickup.

This protractor is manufactured by Burne-Jones and Co., Ltd., Sunningdale Road, Cheam, Surrey, and costs 7s.

# Portable Transistor Receiver

## 2.—CIRCUIT DETAILS

By S. W. AMOS\*, B.Sc.(Hons.), A.M.I.E.E.

A SENSITIVE SUPERHETERODYNE  
CIRCUIT INCORPORATING R.F.  
TRANSISTORS

**T**HE circuit of a portable transistor superheterodyne receiver was discussed in general terms in last month's issue and in this article is examined in detail. The circuit is given in full in Fig. 1 and at first sight may appear complicated, but much of the circuitry is required as a protection against thermal runaway. Protective circuits are important in equipment incorporating transistors and their basic principles will be considered first.

The collector current of a transistor depends not only on the operating voltages but also on the temperature of the junction, increase in temperature causing an increase in collector current. If no precautions are taken, any increase in collector current whether due to a rise in ambient temperature or to a change in operating conditions can cause an increase in collector dissipation which raises the collector temperature, so increasing collector current still further. In this way a regenerative rise in temperature can occur and, if not checked, can cause damage or even destruction of the transistor.

In a class-A stage the dissipation at the collector is a maximum when there is no input signal. If the collector current can be stabilized against changes in ambient temperature under quiescent conditions there can be no danger of thermal runaway when

signals are applied because the collector dissipation then falls. Stabilization of the collector current can be achieved by the potential divider circuit illustrated in Fig. 2. The base of the transistor is given a particular voltage from the junction point of a potential divider  $R_1$   $R_2$  connected across the battery supply. The emitter is connected to the positive terminal of the supply by a resistor  $R_3$  which is bypassed by the capacitor  $C_1$  to avoid feedback and consequent reduction in gain. Under normal operating conditions the emitter of a transistor is usually positive with respect to the base by a small voltage such as 0.1 or 0.2 volt. Thus the voltage across  $R_3$  is slightly smaller than that across  $R_2$ . Provided the potential at the base is constant, the collector current cannot increase, for any tendency to do so results in a decrease of the base-emitter voltage which in turn tends to decrease collector current. The stabilization achieved by this circuit therefore depends on the steadiness of the base potential. If the transistor did not require an input (bias) current the base potential would depend entirely on the battery voltage and the ratio of  $R_1$  to  $R_2$  and stabilization would be perfect. However the transistor does take a base current which passes through  $R_1$  and therefore affects the base potential. However, if the base current is small compared with

\* B.B.C. Engineering Training Department.

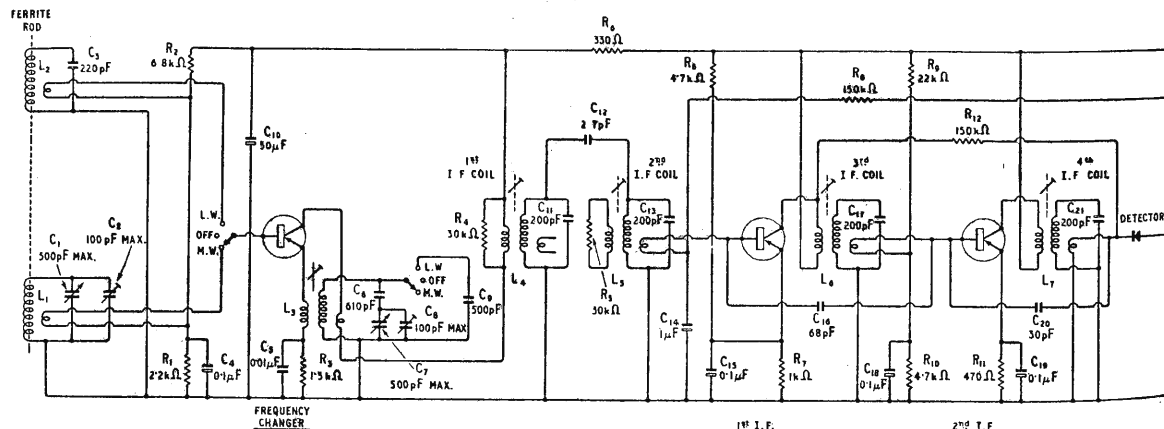

Fig. 1. Complete circuit diagram of portable transistor superheterodyne receiver.

the steady current flowing through  $R_1$  and  $R_2$  from the battery supply, the base potential is not greatly affected by the base current and stabilization is good. It is common practice to make the potential-divider current approximately ten times the base current; this gives good stabilization and the current taken by the potential divider from the battery is usually less than one-third of the transistor collector current and is negligible. This is the type of circuit used to stabilize the collector current of the frequency changer, second i.f. amplifier and driver stages in the receiver.

The component values required in this type of stabilizing circuit can be calculated in the following way. Suppose the collector current is to be stabilized at 1 mA and the current gain of the transistor is 50. The base current is approximately 1/50 mA, i.e. 20  $\mu$ A and the current taken by the potential divider from the battery should not be less than 200  $\mu$ A to give effective stabilization. If the battery supply is 4.5 V the total resistance ( $R_1 + R_2$ ) of the potential divider must be  $4.5 / (200 \times 10^{-6}) = 22.5$  k $\Omega$ . A suitable value for the emitter resistor  $R_3$  is 500 ohms, and, with a collector current of 1 mA, the emitter potential will be -0.5 V with respect to the positive terminal of the supply. If we neglect the potential difference between base and emitter to obtain an approximate answer, the base potential must also be -0.5 V and, to give this the voltage drop across  $R_1$  must be 4 V. The current in  $R_1$  is 220  $\mu$ A (made up of 200  $\mu$ A for the divider chain and 20  $\mu$ A for the base of the transistor) and  $R_1$  is thus given by  $4 / (220 \times 10^{-6}) = 18$  k $\Omega$ .  $R_2$  is thus  $22.5$  k $\Omega$  -  $18$  k $\Omega = 4.5$  k $\Omega$ .

The problem of protecting a class-B amplifier (used in the output stage) against thermal runaway is different. In the absence of an input signal the collector current is small and the heat generated at the collector is low. It increases, however, as the input signal is made larger and such a stage needs protection not only against ambient temperature increases but also against rise of temperature due to increase in the amplitude of the input signal. The heat generated at the collector is a maximum when the output power is approximately 0.4 of the maximum rated value for the transistors. This is an output power level likely to be encountered frequently in practice.

Protection can be provided in two ways, one

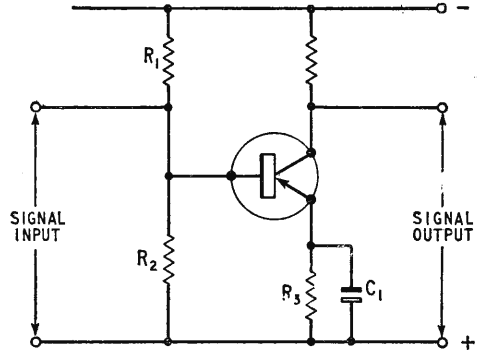
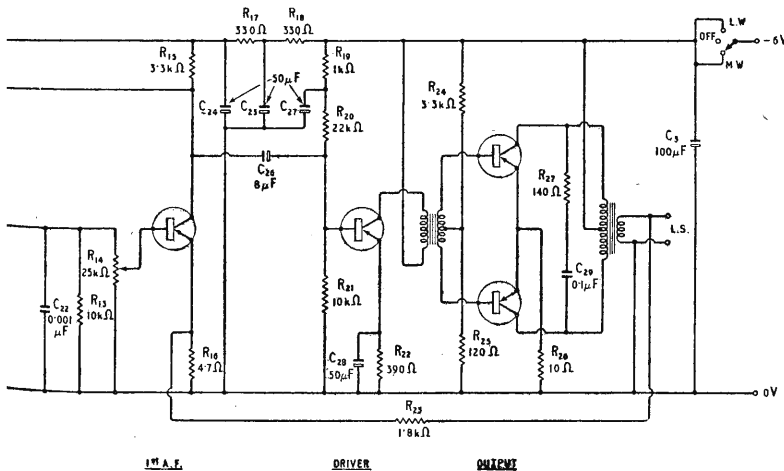

Fig. 2. Potentiometer method of stabilizing the collector current of a transistor amplifier.

mechanical and the other electrical. The mechanical method is to clamp the body of the transistors against a mass of metal having a large thermal capacity and whose temperature cannot therefore change rapidly; a practical method of achieving this is suggested later. Electrically protection can be provided by using the potential divider method just described. Even though the mean collector current of a class-B stage is not constant (as it is in a class-A stage) this circuit can still be used provided the emitter resistance is kept small enough to permit collector currents to rise to 100 mA on peak signals. By using both these methods, effective protection is achieved against thermal runaway due to increase in ambient temperature and to increase in collector dissipation in normal operation. These advantages are not achieved, however, without cost. The use of an external emitter resistance slightly reduces the maximum power output available from the class-B stage but an output of nearly 300 mW can still be obtained at ambient temperatures below 35°C. The inclusion of the resistor reduces the collector-to-collector optimum load resistance to 180 ohms and increases the input current necessary for maximum output, necessitating a collector current of 3 mA in the driver stage.

We shall now examine the circuit of the receiver in detail stage by stage, beginning at the output. The potential divider  $R_{24}R_{25}$  is part of the circuit

protecting against thermal runaway and also provides the base bias necessary to secure a quiescent current of 2 mA in each of the output transistors. The signal-frequency input currents for the output transistors flow in  $R_{25}$  and, to prevent undue loss of signal, this resistor must be small. If it is too small, however, the current taken by the potential divider  $R_{24}R_{25}$  becomes excessive and in the compromise adopted  $R_{25}$  is made 120 ohms. To give the desired quiescent collector currents  $R_{24}$  must be 3.3 k $\Omega$  and the potential divider has a drain of nearly 2 mA from the battery supply. The network  $R_{27}C_{29}$  across the primary winding of



the output transformer is included to improve the output waveform at the high audio frequencies.

The driver stage is conventional, the potential divider  $R_{20}R_{21}$  and emitter resistor  $R_{22}$  being chosen to give a collector current of 3 mA. The reason for the decoupling circuit  $R_{19}C_{27}$ , feeding the potential divider is interesting. This and the decoupling networks  $R_{18}C_{25}$ ,  $R_{17}C_{24}$  in earlier stages, are necessary to minimize harmonic distortion caused by audio harmonics generated in the output stage and fed back to earlier a.f. and pre-detector stages. Each output transistor handles one half of each cycle of input signal; thus the collector current of the output stage includes two pulses for each cycle of input signal. In other words the collector current has a strong second-harmonic component of the signal frequency. This generates across the internal resistance of the battery a voltage which amplitude-modulates the supply to the earlier stages of the receiver, causing harmonic distortion. Even with a new battery the internal resistance is sufficient to cause noticeable distortion and for an old battery the distortion can be severe. The decoupling networks are necessary to minimize distortion due to this cause.

### Automatic Gain Control

The first a.f. stage is coupled to the diode detector by the volume control and coupling capacitor which are arranged to transmit the d.c. component of the diode output to the a.f. stage. This transistor has no source of bias and, in the absence of a signal from the detector, is normally near cut-off, the collector potential being at  $-4.5$  volts with respect to earth. When a signal is tuned-in the negative-going d.c. output of the diode causes the collector current of the transistor to increase and it then amplifies normally. Although this gives a measure of inter-station quieting it was adopted merely for simplicity. The increase in collector current causes the collector potential to fall from the quiescent value. This potential is used as a source of a.g.c. bias by the first i.f. amplifier; thus the first a.f. amplifier acts as a d.c. amplifier for the a.g.c. bias. The emitter of the a.g.c.-controlled i.f. stage is connected to a potential divider across the battery supply which gives an emitter potential of  $-1$  volt approximately. In the absence of a signal the base potential is negative with respect to the emitter potential and the transistor has a collector current nearly 1 mA but when a signal is tuned in the base potential approaches that of the emitter. It cannot equal that of the emitter for if it did so the transistor would be cut off and there would be no i.f. output. Thus the collector potential of the first a.f. stage cannot fall below  $-1$  volt. There is no need for d.c. stabilization because the collector load of  $3.3$  k $\Omega$  limits the collector current to a value of just over 1 mA which gives little collector dissipation.

A.f. feedback is derived from the secondary winding of the output transformer and is injected into the emitter circuit of the first a.f. stage. This feedback is necessary not only to improve the linearity of the a.f. amplifier but also to level the frequency response. The output resistance of the class-B stage is greater than the optimum load and in the absence of feedback the amplifier has a rising high-frequency response similar to that obtained

from a pentode driving a loudspeaker. The emitter resistor of the first a.f. stage must be small for even a value of 20 ohms can cause a noticeable reduction in gain due to current feedback. A value of 4.7 ohms is used. The series resistor  $R_{23}$  determines the overall feedback fraction and the value of this resistor must be chosen with care. To minimize distortion the feedback fraction should be as large as possible but there are two a.f. transformers within the feedback loop and, when more than a particular value of feedback is used, the amplifier goes unstable, usually generating supersonic oscillations. It is therefore desirable to use the lowest value of  $R_{23}$  which gives no danger of instability. The determination of the minimum usable value should be made on a strong signal because this gives maximum gain from the first a.f. stage. If determinations are made on a weak signal the amplifier may go unstable when a strong signal is tuned in. For the particular transistors and transformers used in the author's receiver a value of  $R_{23}$  of 1.8 k $\Omega$  gave complete stability but if different components are used a larger value of  $R_{23}$  may be necessary to avoid instability. Alternatively it may be possible to use a smaller value of  $R_{23}$  without instability.

The input resistance of a common-emitter transistor amplifier is low (approximately 1 k $\Omega$ ) and the design of a preceding detector stage, if capacitively coupled to the amplifier, is particularly difficult. For low distortion operation of a diode detector the ratio of the a.c. resistance of the load to its d.c. resistance should be as high as possible. This requires that the diode load should be small compared with the input resistance of the following amplifier. When this is as low as 1 k $\Omega$  the diode load should ideally be so small to minimize distortion that the diode efficiency is very poor and design of the preceding i.f. coil difficult. Performance can be improved by making the diode load into the volume control for this reduces distortion for all settings except the maximum. However these difficulties can be minimized by d.c. coupling the diode load to the following amplifier and such a coupling is necessary in this receiver to give amplified a.g.c. In fact the diode load used has a value of 10 k $\Omega$  but the a.c. load is larger than the d.c. load over most of the range of the volume control. This is possible partly because of the d.c. coupling and partly because of the negative feedback which increases the a.c. resistance of the first a.f. stage but leaves its d.c. resistance unaffected. A diode load of 10 k $\Omega$  gives reasonable diode efficiency and also gives increased gain compared with that of a circuit using a lower load because the step-down ratio required in the preceding i.f. transformer does not have to be so great.

### I.F. Transformers

In the first part of this article it was explained that the i.f. tuned circuits must be designed as matching transformers and must have high Q values. Pot-type, dust-iron cores were chosen because these readily give the required Q values and in addition give unity coupling between the windings which greatly simplifies calculation of the number of turns required. By using a tuned (secondary) winding of 9/45 Litz wire a Q of nearly 300 is obtainable at 465 kc/s. To resonate with 200 pF, 99 turns are required but silk-covered Litz wire fully

*(Continued on page 343)*

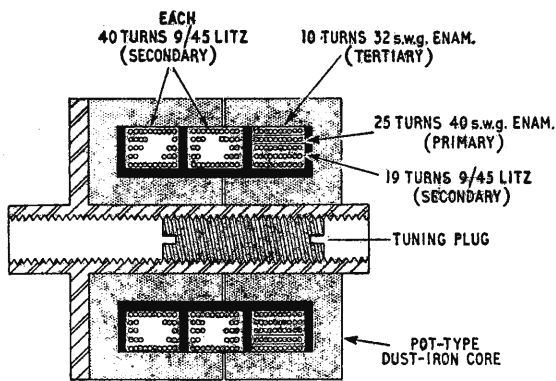

Fig. 3. Winding details of fourth i.f. coil.

occupies all the sections of the former leaving no room for the primary and tertiary windings. However by using 9/45 Litz wire without silk covering† all three windings can be accommodated without difficulty.

The size of the primary and tertiary windings can be calculated in the following manner. The dynamic resistance of the tuned winding is given by  $Q/2\pi fC$  and substituting  $Q = 300$ ,  $f = 465$  kc/s and  $C = 200$  pF gives nearly 480 kΩ. To give the desired working  $Q$  of 100 this is reduced to  $1/3rd$  i.e., 160 kΩ by the damping due to the preceding and following transistors. This is achieved by arranging for the damping due to each of these two sources to amount to 480 kΩ across the secondary winding. This also ensures that the turns ratio of primary to tertiary windings gives correct impedance matching between the output of one transistor and the input of the next. Now the output resistance of the r.f. transistors in the common-emitter arrangement is approximately 30 kΩ and thus the turns ratio between primary and secondary windings must be  $\sqrt{(480/30)} : 1$ , i.e. 4 : 1. The secondary winding has 99 turns and thus the primary must have 25. The damping due to the detector is taken as one half the diode load, i.e., 5 kΩ and the turns ratio between secondary and tertiary windings is  $\sqrt{(480/5)} : 1$ , i.e., approximately 10 : 1. The tertiary winding thus requires 10 turns. The primary winding is of 40 s.w.g. enamelled copper wire and the tertiary is 32 s.w.g. enamelled copper wire although the gauge is unimportant provided the winding can be accommodated on the former. The winding arrangement used is illustrated in Fig. 3 which shows how the primary and tertiary windings are wound over the end of the tuned secondary winding. It is essential that this end of the secondary winding should be earthed. If this precaution is not observed the i.f. coil will show little evidence of resonance and the working  $Q$  value will be very low. Full details of the fourth and other i.f. coils are given at the end of this article. The inductance of the secondary coil can be adjusted by movement of a slug at the centre of the core but the range of adjustment is limited and, even though close-tolerance capacitors may be used across the secondary windings, it sometimes happens that the circuit cannot be brought to resonance at 465 kc/s by adjustment of the slug.

† Supplied in this instance by H. L. Smith & Co. Ltd., 287 Edgware Road, London, W.2.

This can be remedied by adjusting the number of secondary turns but it is easier to adjust the tuning capacitance instead. If the capacitance has to be increased it is usually sufficient to add 10 pF or 20 pF in parallel with the 200 pF capacitor; if the capacitance needs to be decreased a 2,000 pF capacitor can be connected in series with the 200 pF capacitor. The need for capacitance correction is probably connected with the neutralizing circuit.

The collector current of the second i.f. amplifier is stabilized at 1 mA by the potential divider method and the circuit is neutralized by the capacitor  $C_{20}$  connected between the tertiary winding of the final i.f. coil and the base of the transistor. Neutralization is desirable to eliminate the positive feedback which otherwise occurs via the base-collector capacitance. Because the input resistance of the transistor is so low this capacitance may not cause oscillation, but it may affect the symmetry of the i.f. response curve. To offset this internal feedback the neutralizing capacitor must be fed from a source at which i.f. signals are in anti-phase to those at the collector. Thus the connections to the primary and tertiary windings of the fourth i.f. coil must be such that there is phase opposition between the signals at the non-earthly ends. The sense of the windings can usually be found by experiment. If connection of the neutralizing capacitor gives increased gain or oscillation the connections to primary or tertiary windings should be reversed. The value of the neutralizing capacitor can be calculated simply from the ratio of the primary to the tertiary windings and the collector-base capacitance. If the turns ratio were 1 : 1 the neutralizing capacitor should be equal to the collector-base capacitance, say 12 pF. There is, however, a step-down ratio of 2.5 : 1 and the capacitor should hence by  $2.5 \times 12 = 30$  pF. The value is not critical and a fixed capacitor of this value has proved satisfactory.

### First I.F. Amplifier

The circuit of the first i.f. amplifier differs from that of the second because it is controlled from the a.g.c. line. The value of the resistor  $R_s$  should be such that the collector current of the i.f. transistor, in the absence of a signal, is approximately 0.7 mA. If it is made more than this, say 1 mA, automatic gain control is not so effective. The value of the resistor is probably best determined empirically, but it can be calculated in the following manner. If the current gain of the i.f. transistor is 35, the base current for 0.7 mA collector current is  $20 \mu A$ . In the absence of a signal the voltage across  $R_s$  is 3.0 volts, the base being slightly negative with respect to the emitter potential, say -1 volt and the other end at the decoupled supply voltage for the first i.f. stage say -4 volts. The value of the resistor is thus  $3/(20 \times 10^{-6}) = 150$  kΩ.  $C_{14}$  is included to reduce the amplitude of a.f. signals applied to the base from the first a.f. stage. The i.f. coil coupling the first to the second i.f. amplifier has primary and secondary windings similar to those of the fourth coil but the tertiary winding has only 4 turns; this is necessary because the input resistance of the second i.f. stage is much lower than that of the detector. Thus the value of the neutralizing capacitor for the first i.f. stage is  $12 \times 25/4 = 75$  pF. A 68 pF component has proved satisfactory. It is, of course,

again necessary to obtain a phase reversal between signals at the collector of the first i.f. amplifier and the base of the second i.f. amplifier to secure neutralization. These phase relationships also enter into the negative feedback circuit.

As mentioned in the previous article negative feedback is applied over the final i.f. stage in order to obtain a bandpass characteristic from the third and fourth i.f. coils. The signals at the collector and base of a common-emitter amplifier are in antiphase and such feedback could be achieved very simply by connecting a resistor between the collector and the base of the second i.f. amplifier. However the base circuit is of low resistance and, to obtain the feedback required, the resistor would need to be so small that it would constitute a serious shunt of the collector circuit. In place of the base circuit of the second i.f. amplifier we can use the collector circuit of the first i.f. amplifier and here the resistance level is higher—about 10 k $\Omega$ . The feedback resistor cannot, however, be connected directly between the two collectors because the signals at these two points are in phase, due to one phase reversal between the primary and tertiary windings of the i.f. coil and another between base and collector in the second i.f. amplifier. Instead, the feedback resistor is connected between the collector of the first i.f. amplifier and the tertiary winding of the final i.f. coil, which gives the required phase relationship. The value of the feedback resistor can be determined experimentally using an oscillator and wobulator to display the i.f. response curve or can be calculated in the following way.

The maximum gain theoretically obtainable from the i.f. transistors is 36 dB (about 60). Because of the finite Q values of the i.f. coils this is reduced by 4 dB to 32 dB (40). This is the gain measured between two points of equal resistance such as between collector and collector. Between the collector of the first i.f. stage and the tertiary winding of the second i.f. stage the gain is 40/2.5, i.e. 16. To give 6 dB loss (which corresponds to critical coupling) the step-down ratio of the feedback potentiometer must be equal to the reciprocal of this, i.e. 1/16. The collector circuit has a resistance of 10 k $\Omega$  and the feedback resistor  $R_3$  should be 160 k $\Omega$ .

### Frequency Changer

The bandpass filter between the frequency changer and the first i.f. amplifier is composed of two i.f. coils similar to that used between the first and second i.f. amplifiers. Although the first coil does not need a primary winding and the second does not need a primary winding these windings are nevertheless included to avoid the necessity for four different types of i.f. coil. The two coils forming the bandpass filter are each damped by one transistor only and, if nothing were done about this, the working Q would be 150; moreover the Q of the second i.f. coil would rise to nearly 300 in the presence of a large a.g.c. voltage which removes the damping due to the input of the first i.f. stage. Artificial damping is therefore employed to reduce the working Q values to 100 and this takes the form of 30 k $\Omega$  resistors  $R_4$  and  $R_5$  connected across the primary windings. Top-end capacitance coupling is employed in the bandpass filter and a capacitor of 2.7 pF is suitable.

The frequency changer is a single transistor operating as a combined oscillator and mixer. Optimum

conversion gain occurs with a collector current of 0.7 mA and the potentiometer method is used to stabilize the current at this value. The input signal is applied to the base as in other stages of the receiver and oscillation is obtained by coupling the collector to the emitter circuit. A small inductor is included in the collector circuit and another is included in the emitter circuit. Both inductors are unity coupled to a Litz-wound tuned oscillator coil in another dust-iron, pot-type core. For a tuning capacitor of 500 pF maximum capacitance the number of turns required to cover the medium waveband is 39. With a transistor having a high cut-off frequency such as 8 Mc/s the circuit will oscillate when the emitter coil has only two and the collector coil only five turns, but to permit the use of transistors with lower cut-off frequencies the emitter coil should preferably have three and the collector coil seven turns as given in the coil data.

When the receiver is switched to long waves a 500-pF fixed capacitor  $C_3$  is connected in parallel with the oscillator winding to give oscillation at 665 kc/s. Although the medium-wave performance is not materially affected by using an oscillator coil of solid wire the use of Litz wire brings about a significant improvement in long-wave performance.

### Input Circuit

The input resistance of the frequency changer is approximately 1 k $\Omega$  and a small winding is used to couple the medium-wave tuning coil on the ferrite rod to the base input. 50 turns of 9/45 Litz wire are used for the tuned winding which is wound on a paper sleeve free to slide along the ferrite rod. The position of the coil is located during alignment to give an inductance of approximately 160  $\mu$ H. The Q is nearly 300 and the dynamic resistance at 1 Mc/s is 300 k $\Omega$ . To match this to a 1 k $\Omega$  load requires a turns ratio of  $\sqrt{(300/1)}$ : 1, i.e. 17:1. If we assume unity coupling between tuned and coupling windings the latter should have 50/17, i.e. three turns. Experiments with different numbers of turns for the coupling winding confirmed that three turns gives maximum input to the frequency changer. The three turns are wound directly over the earthy end of the tuned winding. It was found that the trimmer capacitors  $C_2$  and  $C_3$  must be of larger capacitance than in a valve receiver and maximum values of 100 pF are desirable. This is presumably because the signal-frequency and oscillator windings are "free", i.e. have no transistor input capacitances directly across them.

The long-wave signal-frequency winding consists of 200 turns of 40 s.w.g. enamelled copper wire close-wound on a paper sleeve mounted on the ferrite rod at the end opposite to that carrying the medium-wave coil. This is tuned by a 220-pF fixed capacitor  $C_3$  and resonance is obtained by sliding the coil along the rod. The number of turns on  $L_1$  and  $L_2$  are so chosen that resonance occurs when the two windings are near the ends of the rod, thus minimizing coupling between them. In practice the inductance of the long-wave coil is approximately 3 mH and the Q approximately 100. At 200 kc/s the dynamic resistance is 400 k $\Omega$  and the matching transformer coupling this winding to the frequency changer needs a turns ratio of 20:1. The coupling coil thus consists of ten turns wound directly over the earthy end of the tuned winding. Full details of both ferrite-

## COIL DATA

### 1st, 2nd and 3rd i.f. coils

Core and former: Neosid type 10D

Secondary winding: 99 turns of 9/45 Litz wire without silk covering, 40 turns in first slot, 40 turns in second slot and 19 turns in third slot.

Primary winding: 25 turns of 40 s.w.g. enamelled copper wire wound in third slot on top of secondary winding.

Tertiary winding: Four turns of 32 s.w.g. enamelled copper wire wound in third slot on top of primary winding.

4th i.f. coil. As above except that tertiary winding is ten turns of 32 s.w.g. enamelled copper wire.

### Oscillator coil

Core and former: Neosid type 10D

Tuned winding: 39 turns of 9/45 Litz wire silk covered wound with 20 turns in first slot and 19 in second slot.

Collector winding: seven turns of 32 s.w.g. enamelled copper wire wound in third slot.

Emitter winding: three turns of 32 s.w.g. enamelled copper wire wound in third slot on top of collector winding.

### Medium-wave signal-frequency Coil

Tuned winding: 50 turns of 9/45 Litz wire silk covered close wound on paper sleeve on ferrite rod.

Coupling winding: three turns of 32 s.w.g. enamelled copper wire close-wound over earthy end of tuned winding.

### Long-wave signal-frequency Coil

Tuned winding: 200 turns of 40 s.w.g. enamelled copper wire close-wound on paper sleeve on ferrite rod.

Coupling winding: ten turns of 32 s.w.g. enamelled copper wire close-wound over earthy end of tuned winding.

### FERRITE ROD

8in long. 3/8in diameter. Mullard type FX 1247.

### TRANSFORMERS

Class-B input Belclere type KS-1cYQ-43

R.F. Gilson type WO 929/6

Class-B output Belclere type KS-00cYQ-21

R.F. Gilson type WO 930/6

### TRANSISTORS

Frequency changer XA 102 TK20A

I.F. amplifiers XA 101 TK20A

Detector CG12E

First a.f. amplifier XB 102 TS2

Driver XB 103 TS3

Output XC 101 TJ2

G.E.C.

GET 3

GET 3

### MINIATURE ELECTROLYTIC CAPACITORS

0.1- $\mu$ F 50-volt working T.C.C. type CE68DA

8- $\mu$ F 6-volt working T.C.C. type CE69A

50- $\mu$ F 12-volt working T.C.C. type CE59BE

100- $\mu$ F 6-volt working T.C.C. type CE59AE

rod windings are given at the end of the article.

In choosing a loudspeaker for a receiver of this type, as in so many radio problems, a compromise solution must be accepted. A 12in diameter loudspeaker adequately baffled and supplied with a 300-mW peak input can produce more than sufficient volume to fill a small living room. However, such a loudspeaker can scarcely be used in a portable receiver and a smaller model must be used in practice. Some tests carried out by the author suggest that a 5in diameter loudspeaker is a suitable size for such a receiver. It can be accommodated easily in a cabinet measuring 9in  $\times$  6in  $\times$  4in, such as is required to hold the horizontal 8in ferrite rod and the battery. Such a loudspeaker can provide reasonable volume, and the reproduction does not suffer from such an obvious lack of bass as that from smaller models.

No mechanical details of the receiver are given because it is probable that constructors may prefer to adopt a physical layout to suit any cabinet that they may have, but the following suggestions for mechanical design may be useful. A convenient method of construction is to mount all components, including the ferrite rod and loudspeaker, on a panel of insulating material which is itself mounted vertically in the cabinet near the front. The components should be secured to the rear of the panel to permit convenient adjustment of dust-iron slugs, trimming capacitors and ferrite-rod windings when the panel is in position. A number of tag strips on the panel provide terminations for coil windings and mountings for components and transistors. Some screening may be necessary between the i.f. coils to prevent instability, particularly if the coils are close together; small earthed metal plates between the coils are usually effective in preventing such instability. The ferrite rod should be mounted horizontally near the top of the sheet, as far as possible from conducting objects such as the loudspeaker, and can be supported in two rub-

ber grommets which should be placed at some distance from the ends of the rod so that they do not prevent the coils  $L_1$  and  $L_2$  being moved along the rod during alignment of the receiver. The grommets can be clamped to the panel by U-shaped wires which fit in the grooves but do not form closed loops around the ferrite rod. The ferrite rod should not be close to the i.f. coils or the detector circuit otherwise there is a danger of i.f. instability.

### Heat Dissipation

It was mentioned earlier that precautions to prevent rapid changes in output transistor temperature are desirable and that the mechanical design of the receiver can be arranged to achieve this. The output transistors can be mounted on a small sheet of 16-gauge aluminium clamped to the paxolin sheet, being push fits in holes drilled in the plate and the paxolin. The metal plate can be secured to the panel by the bolts which hold the class-B input and output transformers in position. In this way the transistors can be placed in thermal contact with a mass of metal having sufficient thermal inertia (product of mass and specific heat) to prevent rapid changes in transistor temperature. The circuit includes a number of capacitors of 50- $\mu$ F capacitance but these need only be rated at 6 volts and miniature electrolytic components are available specifically manufactured for use in equipment using transistors. There are also very small 0.1- $\mu$ F, 50-volt electrolytic capacitors. Type numbers of these are given at the end of the article.

The receiver should be aligned in its cabinet and the procedure is as follows. Connect the output of an a.m. signal generator across  $L_1$ , switch the receiver to medium waves and set the generator to give a modulated output at 465 kc/s. Adjust the i.f. coils to give maximum output from the receiver working all the time with a very small



i.f. input to avoid the masking effect of a.g.c. If indication of the output is wanted a meter measuring the collector current of the output stage or of the a.g.c.-controlled i.f. stage can be used. The adjustments are carried out to give maximum collector current in the output stage or minimum current in the i.f. stage. The current changes in the i.f. stage will be rather indeterminate if the input signal is such as to reduce the collector current of this stage to near zero and it is preferable to reduce the output from the signal generator to give a collector current only slightly less than the no-signal value.

Now set the signal generator to 1.6 Mc/s and connect the output to a few turns of wire looped around the ferrite rod near the long-wave coil. Set the receiver tuning capacitor to minimum and tune in the signal by adjustment of  $C_3$ . Set the signal generator to 550 kc/s and the receiver tuning capacitor to maximum and tune in the signal by adjustment of  $L_3$ . Now repeat the adjustments at 1.6 Mc/s and 550 kc/s and continue repeating them until no further adjustment is required. The medium-wave frequency coverage of the receiver is now correct.

Set the signal generator to 1.53 Mc/s and tune in the signal on the receiver. Now adjust  $C_2$  to give maximum output. Set the signal generator to 620 kc/s, tune in the signal on the receiver and slide  $L_1$  along the ferrite rod to give maximum output. Repeat the adjustments at 1.53 Mc/s and 620 kc/s and continue repeating them until no further adjustment is required. The medium-wave alignment is now complete and the paper sleeve of  $L_1$  should be fixed to the ferrite rod.

The long-wave alignment is best carried out on the B.B.C. transmission from Droitwich. Switch the receiver to the long waves, tune in the long-wave station and adjust  $L_2$  by sliding the paper sleeve along the rod to give maximum output. Finally secure the sleeve to the rod at the optimum position.

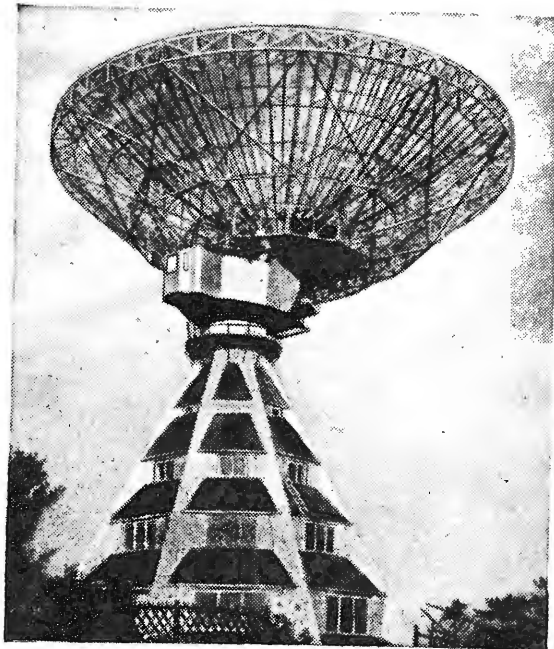

German Radio Telescope nearing completion on Mount Stockert has been constructed under the supervision of Telefunken for the University of Bonn. It will be used for studying radio noise emissions from space, particularly those from interstellar gas on about 21 cm, and also for radar research. The 820-ft paraboloid is steered automatically by servo-mechanisms under the continuous control of co-ordinate computers, and for tracking purposes can move at the rate of 1 degree per second. The receiving equipment has to deal with noise signals which are one or two orders of magnitude below its own noise background. For this a differential measuring technique is used in which a 500-c/s sampling system compares a local signal plus local noise with another local signal plus received noise and local noise. Full details are given in Telefunken Zeitung for September, 1956.

## SHORT-WAVE CONDITIONS

Prediction for July

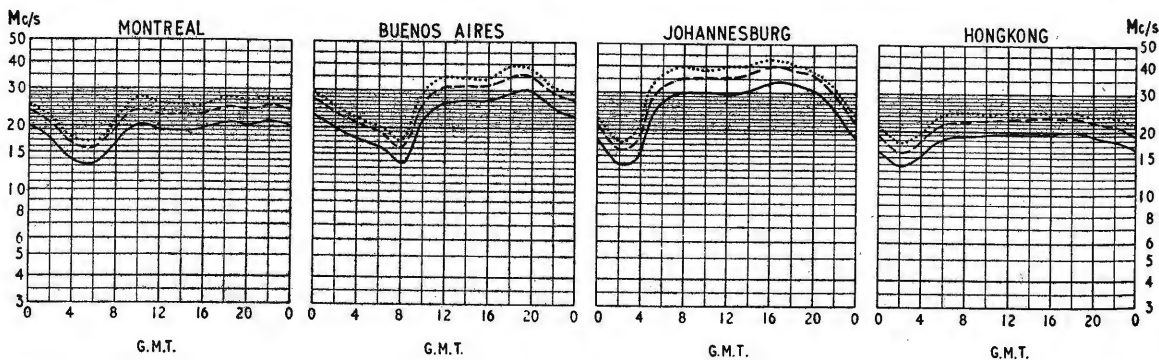

THE full curves given here indicate the highest frequencies likely to be usable at any time of the day or night for reliable communications over four long-distance paths from this country during July.

Broken-line curves give the highest frequencies that will sustain a partial service throughout the same period.

- ..... FREQUENCY BELOW WHICH COMMUNICATION SHOULD BE POSSIBLE FOR 25% OF THE TOTAL TIME
- - - - PREDICTED AVERAGE MAXIMUM USABLE FREQUENCY
- FREQUENCY BELOW WHICH COMMUNICATION SHOULD BE POSSIBLE ON ALL UNDISTURBED DAYS

# LETTERS TO THE EDITOR

*The Editor does not necessarily endorse the opinions expressed by his correspondents*

## "Off the Record"

FOR 30 years or so I have been studying *Wireless World* and endeavouring to improve my standards of domestic reproduction thereby; and for some time now my ears, even with the merciful filtering of the falling top response of age, have convinced me that the present L.P. disc is not a suitable medium for the repeated reproduction of a piece of good music. Having learnt in the last two issues of your journal some of the reasons why, I am disconcerted to read in your June editorial that we should, after all, be well satisfied.

This leader seems to waver a little towards the end; for the sake of a valuable emotional experience we can, you aver, accept even a severe degree of harmonic distortion.\* This may well be true for one or two hearings, but after a few repeats severe harmonic distortion becomes like a raging toothache, destructive of all pleasure and enjoyment. To record Toscanini's *Eroica* was a service to posterity, but it has not, in my opinion, resulted in something that the average music lover can continue to play with any enjoyment.

We all owe the gramophone companies a great deal for the cultural standards they have maintained, but much of the gramophone Press these days suggests a mutual admiration society; if *W.W.* join the chorus the improvement necessary for our happiness may be needlessly delayed.

Tape quality appears to be comparable to that of a good f.m. broadcast, whilst this latter is beyond question much superior to that of the disc. Here surely is a challenge that the gramophone must meet.

Felixstowe.

L. E. SMITH.

[\* We did not advocate the voluntary acceptance of audible distortion; our point was that in some circumstances it introduces no incongruity and passes unnoticed.—Ed.]

WHILE it may sometimes be desirable to "edit" orchestral and choral performances for recording purposes, Mr. Salter's suggestion, recorded in your report last month of the National Gramophone Conference, that it is legitimate to use the volume control to fade a choir in a manner incapable of performance by any existing choir is surely appalling; once such practices are established, where will they end?

If this is reasonable, it is equally so, for instance, to adjust tape speed and choir tempo so that the sopranos appear to produce an impossibly high note, or use the tone controls to produce from an orchestra sounds that no instrument ever created; there is no limit to the ways in which such practices can spread.

Already, I understand, top notes sung by someone else have been dubbed into performances by popular but fading singers. Such records may be interesting stunts, but their artistic level is that of the *Dogs' Chorus*.

Richmond.

BARRY J. DAVIS.

## Television Coverage

A LOGICAL method of dealing with the situation complained of by T. Payne in your June issue is the use of a wired method of distribution.

Television relay systems employing carrier technique and "amplified aerial" networks enable many thousands of licence-holders to obtain satisfactory viewing in areas where B.B.C. and I.T.A. field strengths are low, by reason of their distance from the transmitters and the shadow effect of high ground. Correspondingly, in towns where field strengths are high, a master receiving station with carefully designed aerial arrays can eliminate reflections and can feed satisfactory signals over a cable network to subscribers' homes.

In addition to the reason already mentioned, wired distribution will surely achieve increasing importance owing to the lack of channels in the TV frequency spectrum. Already in Southern England we experience interference with I.T.A. transmissions on channel 9 by the Winter Hill transmitter, which is also, of course, on channel 9. The problem is not likely to become easier and one can therefore envisage the time when many programmes will be transmitted over long-distance cable links to central amplifier stations in all the larger towns and then distributed by means of wired systems.

Portslade-by-Sea, Sussex.

D. C. BOND.

## Colour Television

REGARDING reports of the disappointingly slow development of colour television in U.S.A., I would like to make the following comments.

I have seen colour transmissions during the last few months in Chicago and New York, and although technically the pictures were reasonably good, one is left with a vague impression of something lacking. During a visit to station WNBQ in Chicago I spoke to a few people who were watching a colour programme and their reactions, to put it mildly, were far from enthusiastic.

In order to test a theory I had regarding this inexplicable lack of interest by the general public, I made the following experiment. A number of friends were invited to see some home movies in colour then in black and white. The size of the projected picture was then varied at intervals from about one foot in width to six feet. I then asked each viewer: "What would be the minimum size of picture that you would tolerate for ordinary home viewing?" The results were interesting. With black and white film the answers ranged from one to two feet, while with colour, the answers were from three to four feet. This might indicate the key to the problem of general apathy to colour television. It would seem that a larger screen is the answer.

Now, in U.S.A. and Canada, about 90 per cent of receivers are 21-inch with the 24- and 29-inch screens slowly pulling up. I suggest that the sales of colour receivers will start climbing rapidly if and when screens of 30 to 40 inches, or even larger, can be used.

I disagree completely with the contention that the high price is a deterring factor. On the contrary I believe that sales would start shooting up even if the price was as high as three times that of the black and white receiver.

SIDNEY GOULD.

Montreal.

# News from the Industry

**G.E.C.** has been awarded a £25,000 contract by the Ministry of Supply for the supply of Government versions of the Z77 screened pentode. The contract calls for "fully-reliable" valves for operation under arduous conditions of mechanical shock and vibration.

**Marine f.m. radio-telephone** equipment manufactured by Storno, a division of the Great Northern Telegraph Company, of Denmark, is being marketed in this country and in many British territories overseas by Cossor Communications Company. As announced in our last issue the first British f.m. radio-telephone station has been opened in the Clyde estuary.

**Fret Fabric.**—Simpson & Godlee, textile manufacturers of 30 Princess Street, Manchester 1, have produced a loudspeaker fret fabric which is marketed under the Company's brand name of Simplan. It is a rigid open-weave fibre fabric which, it is claimed, is unaffected by heat up to 220 degree F.

A polythene film sleeve produced by British Cellophane, Ltd., is now used by the B.B.C. to protect the long-playing records for its transcription service to overseas broadcasting organizations. The film, which forms a lining to the normal paper sleeve, leaves the "title circle" in the centre visible, and when sealed provides a completely dust-proof cover.

**Polythene self-adhesive tape** for electrical insulating purposes is now being marketed by the Industrial Sellotape Division of Gordon and Gotch, 8-10 Paul Street, London, E.C.2.

"Visqueen," polythene film covers, supplied by the Paper Goods Manufacturing Co. are now being used by Murphy Radio in the packing of a number of their television sets.

**Ekco Electronics, Ltd.**, are supplying three auto-standardization nucleonic "substance" gauges to the Bowater Organization. Two of the gauges are being installed on paper machines at the Sittingbourne and Kemsley Divisions, and the third will be used by the Research Division.

**Rhoden Partners, Ltd.**, of 51, North Row, London, W.1, provide a service for the design and development of specialized manufacturing equipment. They are not themselves manufacturers, but will undertake the design of new equipment or modifications to existing assembly lines necessitated by the introduction of, for instance, printed circuitry.

**British Relay Wireless** installed a closed-circuit television system in the Imperial College of Science and Technology, Kensington, so that the ceremony of unveiling a memorial plaque by H.M. The Queen Mother, could be seen by staff and students in the various buildings comprising the College. Some 30 monitors were used.

**Coastal Radio, Ltd.**, announce that their new Stentor/Comet radio-telephone (Type 290), designed primarily for fishing vessels, small cargo ships and yachts, is now in production. Type approved by the G.P.O. for "voluntary fitted" ships up to 500 tons gross, the 50-watt transmitter can be supplied to operate on either 5 or 8 crystal-controlled frequencies between 1,600 and 3,700 kc/s. It provides for either simplex or duplex operation. The receiver covers the long- and medium-wave broadcasting bands in addition to the small craft radio-telephone band.

**Eleseo Electronics, Ltd.**, of Glasgow, associates of Land, Speight & Co., have appointed J. Grenville Robertson as technical sales manager in succession to W. O. Buchanan who has gone to Stow College. Mr. Robertson was for many years with the English Electric Company.

## EXPORT NEWS

**Overseas Markets.**—The U.S.A. was the biggest purchaser of British radio equipment last year. Its imports totalled over £3.2M of which about 75 per cent was sound reproducing equipment. Australia was second with nearly £3M worth, and the Netherlands third (£2.8M). An analysis prepared by the Radio Industry Council shows that 38.8 per cent of our £40M worth of exported equipment went to British Commonwealth countries, 38.6 per cent to Europe, and 9.6 per cent to North America.

**Surveillance radar** (Type CR21) is to be installed by Cossor Radar and Electronics, Ltd., for the Australian Ministry of Civil Aviation at the Sydney and Melbourne airports.

**Rediffusion.**—A wire-distribution television service has been introduced by Rediffusion in Hong Kong where they have operated a sound service since 1949. The British 405-line standards are employed. The vision carrier frequency is 4.95Mc/s, sound being distributed at a.f. over the same network. A studio equipped with five camera chains and three film scanners has been set up.

**G.E.C.-Fielding** r.f. edge-gluing equipment for making up panels from strips of wood has been supplied to Russia. Except for the application of the glue to the strips before assembly the whole process is automatic.

"**Elletra II**," the radio research and demonstration vessel of the Marconi Marine Company, is completing a six-week tour of Continental ports.

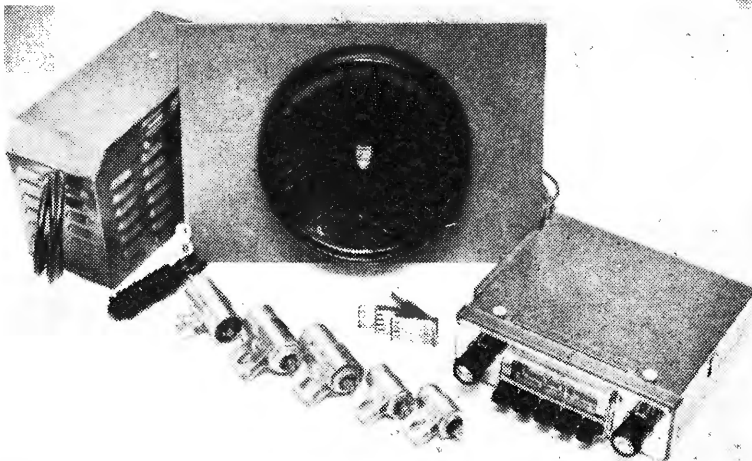

**F.M./A.M. CAR RADIO.**—The new Philips a.m./f.m. car radio (including loudspeaker, power supply and suppression equipment), believed to be the first of its kind in England, employs seven valves (+rectifier) for long, medium and f.m. wavebands. There is also an outlet socket for operating the 'Philishave' electric shaver. Philips have found an ordinary car aerial (preferably about 40 in long) satisfactory for use with this set. The price is 49 guineas including purchase tax.



**PROTECTION FOR C.R. TUBES.**—A new packing method, devised jointly by Venesta and Evans Bellhouse, uses a plywood outer barrel with an inner protective packing of wood-wool, suitably impregnated and moulded to shape.

**Multi-channel R/T equipment** is being supplied by Pye Telecommunications to the Socony Mobil Oil Company, of Venezuela. It will link the company's head offices in Anaco and an oil field at Guico, 25 miles away. The f.m. system, which will be linked into the public telephone service, will provide six channels over one pair of carriers.

**Telegraph Equipment for Turkey.**—Thirty-three telegraph distortion measuring sets, for the detection of faults and distortion on line and radio teleprinter circuits, are being supplied by Automatic Telephone & Electric Company to Societa Tetetra, of Milan, for installation in Turkey.

## CLUB NEWS

**Birmingham.**—Slot beam aerials will be demonstrated to members of the Midland Amateur Radio Society by B. Sykes (G2HCG) of J. Beam Aerials, Ltd., at the club meeting on July 16th. Meetings are held at 7.30 in the Midland Institute, Paradise Street. Sec.: C. J. Haycock (G3JJD), 360, Portland Road, Birmingham 17.

**Nottingham.**—The Amateur Radio Club of Nottingham (G3EKW) meets each Tuesday at 7.15 at Woodthorpe House, Mansfield Road. Present activities include the building of transmitting and receiving equipment and the provision of slow Morse practice periods both in the club room and, at weekends, over the air. Sec.: F. V. Farnsworth, 32, Harrow Road, West Bridgford, Nottingham.

**Downham.**—Preparations are in hand by the Ravensbourne Amateur Radio Club to conduct a radio course

**Marine R/T.**—The new 500-ton port tender, the *Salam*, being fitted out in Dartmouth for the Government of Zanzibar, will be equipped by Woodsons, of Aberdeen, with their "Clipper" radio-telephone and d.f. unit.

## WORKS EXPANSION

**Electrothermal Engineering, Ltd.**, of 270 Neville Road, London, E.7, have taken over a factory in Southend, Essex. The additional 10,000 square feet of manufacturing space will be used by the components section and industrial heating division.

**Venner Accumulators, Ltd.**, which formerly occupied a section of the main Venner factory on the Kingston By-Pass, have now taken over a whole floor (6,000 square feet) of a new building on the same site.

**Electronics Division of Gresham Transformers, Ltd.**, of Hanworth, Middlesex, has been transferred to Lion Works, Hanworth Trading Estate, Feltham, Middlesex. (Tel.: Feltham 6661.)

## NEW ADDRESSES

**Burne-Jones**, manufacturers of radio and electronic equipment, have moved from south-east London to Sunningdale Road, Cheam, Surrey. (Tel.: Fairlands 8866.)

**Communication Systems, Ltd.**, a member of the A.T. and E. group, has transferred its Bristol office and maintenance depot to Strowger House, 2, St. Paul's Road. (Tel.: Bristol 33088-9.)

**Marconi Marine's** Northern Ireland depot is now at Marconi House, Corporation Square, Belfast.

for beginners in September. One member of the club has obtained his amateur TV transmitting licence (G3LNT/T). The club meets each Wednesday at 8.0 in the Science Room, Durham Hill School, Downham, Kent. Sec.: J. H. F. Wilshaw, 4, Station Road, Bromley, Kent.

**Sidcup.**—The next meeting of the Cray Valley Radio Club will be held on the publication date of this issue, June 25th, at 8.0 at the Station Hotel, Sidcup. A film lecture will be given by Mullah. Sec.: S. W. Coursey (G3JJC), 49, Dulverton Road, London, S.E.9.

**British Two-Call Club.**—The new president of this club, membership of which is limited to those who have held an overseas call sign and one in this country, is K. E. S. Ellis (G5KW) and the vice-president Jack Cooper (G3DPS). Sec.: G. V. Haylock (G2DHV), 63, Lewisham Hill, London, S.E.13.

new

# TRIX DYNAMIC MICROPHONE



THE MICROPHONE ILLUSTRATED is our new type G7850, a dynamic microphone of outstanding contemporary design. It is finished in bronze black, carries a ring-locking plug connector and is suitable for hand and stand use. Owing to its exceptional top response characteristic, it gives particularly good reproduction of speech and this, allied to its distinguished looks, will make it a welcome and handsome addition to our range of Sound Reproducing Equipment. (Dimensions: Head diam. 1½ in.; Overall length 8½ in.)

Price: 15 gns.

Please write for full details of our complete range of Sound Reproducing Equipment.

a product of

TRIX ELECTRICAL COMPANY LTD.

1-5 Maple Place, Tottenham Court Road,  
London W. 1

Tel: MUSEum 5817 Grams: Trixadio Wesdo London

P277

# RANDOM RADIATIONS

By "DIALLIST"

## Higher and Higher?

TO MY way of thinking, at any rate, the future of sound broadcasting doesn't lie on the long or the medium waves. Some people hold that sound broadcasting hasn't much of a future anyhow, believing that it will eventually be entirely superseded by television. But I can't agree with that, for some things such as concerts are probably more pleasing if they're heard without being seen as well—unless of course you have a professional interest and want to watch the conductor and the technique of the players. I've an idea that sound broadcasting will go on for a long time to come and that f.m. services on Band II, or on even higher frequencies will gradually replace most of the present long- and medium-wave a.m. systems. Both of these bands are subject to atmospheric interference and are so badly overcrowded that mutual interference between stations is rife. Worst of all, the very narrow channels which must of necessity be used make really high quality out of the question.

## What of TV?

What I feel about television is that it too should begin to look to the higher frequencies of Bands IV and V. When the Television Committee produced its report towards the end

of the war one of its recommendations was, if you remember, that efforts should be made to develop a system of the order of 1,000 lines, the present 405-line system being carried on as well for some years. Why shouldn't we do that by continuing the B.B.C. and I.T.A. services as they are and by gradually building up services at least as good as the French with its 819 lines on the higher frequencies? The cost should not be enormous, for the same programmes could be sent out by both the 405-line and the 1000-line (let's call it that for convenience) services. If 1000-line cameras were used in all studios, conversion to 405 lines for the Band I and Band III services could be made by the methods now used for the Eurovision programmes. No receivers would be rendered obsolete and the purchase of 1000-line sets would be purely a matter of choice.

## The Interference Problem

Then there's the business of interference, which in many places is now so severe that there's little pleasure in viewing. Would not that caused by motor vehicle ignition systems and by electrically driven machinery be less troublesome on the higher frequencies? And interference radiated by other receivers? The greater field-strengths for the higher

frequencies tolerated in the standards accepted by both British and American set manufacturers suggest that it would be reduced. And there are two other interference problems associated with Band I. The first is that of mutual interference between stations at a considerable distance from one another: Norwich disturbs the Liège pictures, unless its power is kept quite low, and viewers living on or near the south and south-west coasts know what a nuisance the Caen station can be. These may be "freak" effects due to sunspot activity; we shall know in a few years time as the maximum period is left behind. But there's nothing freakish about the second bit of bother, patterning caused by f.m. sound transmissions from the same aerial mast. The use of much higher frequencies for television should mean shorter ranges and therefore less risk of interstation interference and I've an idea that it should be possible to eliminate the patterning mentioned by the very careful choice of each station's TV frequencies.

## Measuring by Wireless Waves

THE degree of accuracy with which distances can be measured by radar, by the Tellurometer and other methods making use of radio waves, must depend, when you come to think of it, on two things. You must know the precise speed of radio waves through air and you must be able to time a particular journey that they make correctly to a tiny fraction of a microsecond. The speed of radio and light waves has been investigated many times, but no two investigations have so far produced exactly the same answer. The differences are minute; still they are differences and I am tempted to wonder whether the speed does in fact remain always fixed and unchanging. With modern apparatus times can be measured with an accuracy better than  $10^{-9}$  second. Then even if there is a minute variation in the speed of wireless waves and a similarly minute error in the timing, surveyors and geographers can now pin-point positions to within a few centimetres at the very outside. But do things on the surface of this earth of ours stay



## "WIRELESS WORLD" PUBLICATIONS

	Net Price	By Post
ABACS OR NOMOGRAMS: A. Glet. Translated from the French by H. D. Phippen and J. W. Head ...	35/-	35/10
TELEVISION RECEIVING EQUIPMENT. W. T. Cocking, M.I.E.E. 4th Edition ...	30/-	31/6
FOUNDATIONS OF WIRELESS. M. G. Scroggie, B.Sc., M.I.E.E. 6th Edition ...	12/6	13/6
WIRELESS SERVICING MANUAL. W. T. Cocking, M.I.E.E. 9th Edition ...	17/6	18/6
RADIO VALVE DATA: Characteristics of over 2,500 Valves, Transistors and C.R. Tubes. Compiled by <i>Wireless World</i> ...	5/-	5/7
SECOND THOUGHTS ON RADIO THEORY. "Cathode Ray" of <i>Wireless World</i> ...	25/-	26/2
RADIO LABORATORY HANDBOOK. M. G. Scroggie, B.Sc., M.I.E.E. 6th Edition ...	25/-	26/6
ELECTRONIC COMPUTERS: Principles and Applications Edited by T. E. Ivall ...	25/-	25/9
THE OSCILLOSCOPE AT WORK. A. Haas and R. W. Hallows, M.A. (Cantab.), M.I.E.E. ...	15/-	15/10
TRANSISTORS: Circuits and Servicing. B. R. Bettridge ...	2/6	2/8

A complete list of books is available on application

Obtainable from all leading booksellers or from

ILIFFE & SONS LTD., Dorset House, Stamford Street, London, S.E.1



exactly put? It doesn't seem impossible that there should be very small tidal movements in the land, as well as the vastly greater ones in the sea. It wouldn't surprise me if as time goes on it's discovered that no point on earth has an immutably fixed position. Is there geographical as well as TV spot-wobble?

### *X-rays from the Sun*

THE Geophysical Year, which starts on July 1st, is bound to increase to an important extent our knowledge of the long-distance propagation of wireless waves. One rather surprising discovery has already been made on the other side of the Atlantic during experimental tests of rocket-borne instruments. This is that at times of great solar activity, and particularly when flares occur, X-rays from the sun penetrate the upper layers of the atmosphere. Measurements so far made at heights up to 60 miles show that a few minutes after the appearance of even a small flare the quantity of X-radiation received may be sufficient to double the electron density at such altitudes. It is suggested that further observations at greater heights may show that this solar X-radiation is responsible for fading and black-outs on the short waves. It may, in fact, turn the Heaviside and Appleton layers temporarily into absorbers instead of reflectors of wireless waves. It has, of course, long been known that radiation from the sun was responsible for interrupting long-distance communications; but, so far as I know, it hadn't been discovered that this included any appreciable amount of X-rays.

### *Useful in the Workshop*

DO YOU, I wonder, know and use that very useful piece of workshop equipment, the file card? The name at first glance might suggest something for office use; actually it's an array of claw-shaped thin steel wires mounted on a stout cloth backing and is used in the textile industry for "carding" wool. Most of us have an aversion from using good files on soft metals for fear of clogging them up. If you have a file card and use it, there's no need to worry. The claws soon clean away any bits of soft metal and leave the teeth of the file clean and sharp. File card can be bought from most ironmongers by the piece from which a strip is cut and fastened by screws to a flat piece of wood. Besides its main use it is very effective for cleaning the cutter wheel of your cigarette lighter.

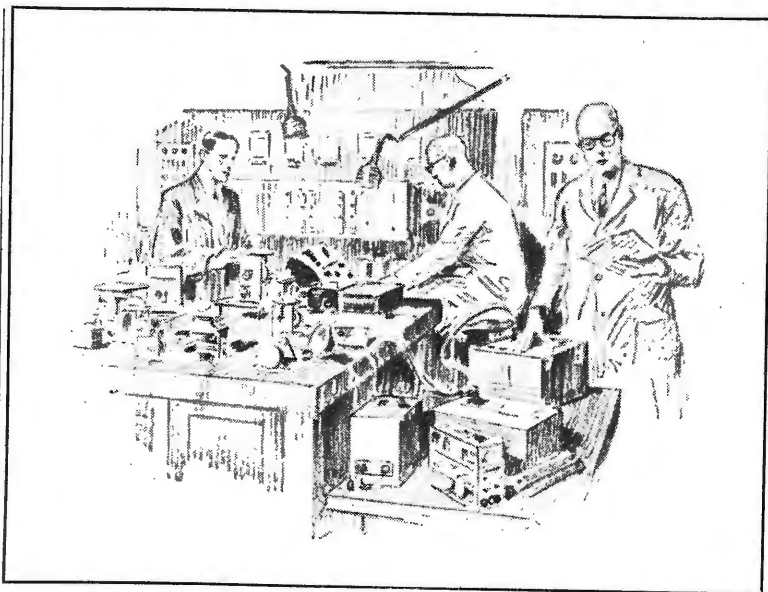

## Electronic components FOR ALL INDUSTRIES

(RESEARCH)

Used in the thousands of sensitive instruments which today control the processes of modern industry, BULGIN electronic components are helping to overcome problems in the industrial and scientific fields, and are faithfully serving the majority of the Country's greatest organisations. The Bulgin research department and its manufacturing units with their unique skills and experience build good electronic components upon which you can depend. Over 10,000 different components are available.

★ For full details of Bulgin Components send for fully illustrated Catalogue 196/WW (free to trade letter-heading or order).

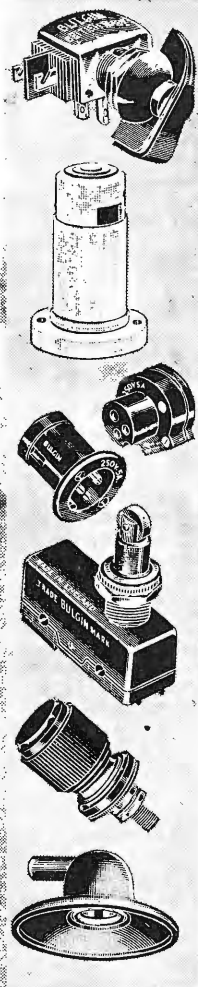

THE HOUSE OF  
**BULGIN**

A. F. BULGIN & CO., LTD.



BARKING, ESSEX.

Tel.: RIPPleway 5588

MANUFACTURERS OF RADIO AND ELECTRONIC COMPONENTS

## Horseless-Carriage TV

I FULLY agree with "Diallist's" complaint (June issue) about the difficulties of viewing in comfort because of the insufficient height of the screen in a console TV set. I tried to solve this problem years ago by building my own set into a disused grandfather clock case, the screen being where the dial is normally.

The screen was then much too high but I corrected this by buying a couple of dentist's chairs for Mrs. Free Grid and myself. These enabled us to tilt ourselves into a comfortable viewing position. However, Mrs. Free Grid took a strong dislike to this arrangement, as sitting in the dreaded chair brought painful memories to her which became unbearably realistic whenever a screeching soprano appeared on the screen.

The truth of the matter is that both "Diallist" and I have failed to realize that TV is now emerging from its "horseless carriage" era. Console and table receivers have served their purpose and it is time that we consigned them to the dustbin. TV sets—and sound-radio ones too—must go to the wall; in other words they must be built-in.

For rooms in the smaller type of house this is a necessity, while even in the largest rooms it is a great convenience. It may be objected that TV tubes are too long, and that my idea would mean that the tail of the tube would stick out of the wall into the adjoining room. Even if that were so, of course, it could at least be used as a support for a picture but in actual fact the full-size tube is on its way out. The set of the future will be of the projection type using a miniature c.r.t. Thus the set and its tube will be built into one wall of the room and the screen in the opposite wall, the beam being shot above the heads of the viewers.

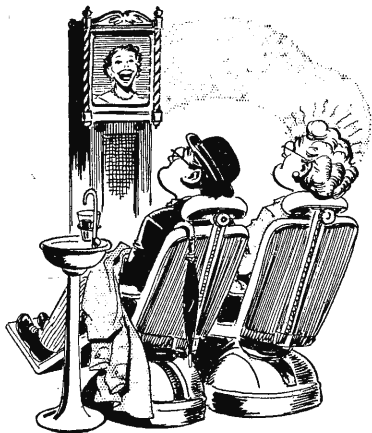

Viewing in comfort

For sound broadcasting, a built-in set would be ideal as the loudspeaker could do double duty, the two sides of the diaphragm feeding the programme into rooms on both sides of the wall, which would act as a perfect baffle.

## The Radiotherm

IN the March issue I mentioned that I was thinking of discarding my electric blanket in favour of the electronic-cooking technique of keeping myself warm in bed.

I really thought I was on to something entirely original, but I have received a very interesting letter from a medical pundit of Portsmouth, who tells me that there is nothing new in my idea of torso toasting by electronic means. His own experience of it dates back to the early part of the war. I am reminded, too, that the correct name of the apparatus used is radiotherm and not torsothermer, as I suggested.

I dare say many of you have heard of the treatment of certain diseases of the central nervous system by means of an artificial fever. In 1917 it was done by injecting the patient with malaria, but later an electrically heated cabinet was used to raise the patient's temperature. Eventually electronic means were used, the patient's temperature being raised by induction of r.f. currents in his body, care being taken not to devil his kidneys or parboil his pancreas.

Whether he intended to do so or not, my medical correspondent has put me off the whole business, and I shall stick to my electric blanket.

## Decibel Dousing

FROM time to time I have protested in these columns about the reprehensible practice of the B.B.C. of switching over from a quiet item like "Mrs. Dale's Diary" to Sousa in full blast without any apparent effort on the part of the control-room engineer to even things out.

If we adjust our volume control so that Mrs. Dale's voice is at a pleasant conversational level we are nearly blasted out of our seats when Sousa is let loose on us. Then, having jumped up and softened Sousa the announcer is barely audible when he tells us about the next item. Whenever I have protested, however, I have been assailed on all sides by those readers of *W.W.* who are music lovers. They point out that the B.B.C. control-room is right and I am wrong, for in real life Mrs. Dale cannot and does not compete with Sousa in the decibel stakes.

I am perfectly well aware that I am a musical Philistine but there are many millions like me and it is

shameful that we should have to be sacrificed to make a Roman holiday for music lovers. Fortunately I have found the ideal way out of the difficulty whereby we can all get what we want rather than what the B.B.C. thinks is good for us.

My idea is based on the American technique, already described in these columns, whereby certain transmitters radiate a special muting signal on another frequency when they are broadcasting interlarded advertisements, which even some Americans find irritating. This signal is picked up by all receivers fitted with the necessary extra apparatus and used to mute the loudspeaker until the advertiser's announcement is ended.

The B.B.C. could easily radiate a similar signal which, by suitable arrangements in the sets of us Philistines, could be used to turn down the wick of our receivers, and so reduce Sousa and his sound-barrier-breaking brass to Mrs. Dale's level. Can you see any snags in my decibel dousing idea?

## Radio Fluologist

CAN any of you tell me why a chimney sweep always seems to describe himself on his signboard as a practical chimney sweep. The O.E.D. tells me that one of the subsidiary meanings of the word practical is best illustrated in the sentence "practical politics is to do what you can and not what you ought."

I can hardly believe, however, that the synthetic negroes who sweep our chimneys read the O.E.D. or have anything in common with Oxford. On the contrary, one of them who has appeared in the news recently is obviously a Cambridge man as he is an outstanding scion of science. He has shown this by equipping himself with mobile radio. His wife operates the H.Q. transmitter and he is able to receive his late orders without returning home.

I naturally suppose that in addition to the main apparatus in his van he carries a battery-operated transmitter-receiver strapped to his person for use when actually at work as he is then in a unique position to employ a really efficient aerial. Obviously he could have his rods specially made as a concentric feeder. These rods would pass through the operating brush and continue on to a simple rod aerial sticking out of the chimney.

Thus he is really entitled to call himself a practical chimney sweep in the fundamental sense of the word. But does he do so? Not on your life, for he describes himself by the new horror-word "fluologist" as do many of those who, unlike himself, have adopted the new vacuum-cleaner method of cleaning our chimneys.